

**Marking Directions:** Mark only **one** oval for each question. Fill in response completely. Erase errors cleanly without smudging.

**Correct mark:**

**Do NOT use these incorrect or bad marks.**

Incorrect marks:

Overlapping mark:

Cross-out mark:

Smudged erasure:

Mark is too light:

**BOOKLET NUMBER**

1	1	1	1	1	1
2	2	2	2	2	2
3	3	3	3	3	3
4	4	4	4	4	4
5	5	5	5	5	5
6	6	6	6	6	6
7	7	7	7	7	7
8	8	8	8	8	8
9	9	9	9	9	9
0	0	0	0	0	0

**FORM**

--	--	--

67C

Print your 3-character **Test Form** in the boxes above and fill in the corresponding oval at the right.

**TEST 1**

- |              |              |              |              |              |              |
|--------------|--------------|--------------|--------------|--------------|--------------|
| 1 (A B C D)  | 14 (F G H J) | 27 (A B C D) | 40 (F G H J) | 53 (A B C D) | 66 (F G H J) |
| 2 (F G H J)  | 15 (A B C D) | 28 (F G H J) | 41 (A B C D) | 54 (F G H J) | 67 (A B C D) |
| 3 (A B C D)  | 16 (F G H J) | 29 (A B C D) | 42 (F G H J) | 55 (A B C D) | 68 (F G H J) |
| 4 (F G H J)  | 17 (A B C D) | 30 (F G H J) | 43 (A B C D) | 56 (F G H J) | 69 (A B C D) |
| 5 (A B C D)  | 18 (F G H J) | 31 (A B C D) | 44 (F G H J) | 57 (A B C D) | 70 (F G H J) |
| 6 (F G H J)  | 19 (A B C D) | 32 (F G H J) | 45 (A B C D) | 58 (F G H J) | 71 (A B C D) |
| 7 (A B C D)  | 20 (F G H J) | 33 (A B C D) | 46 (F G H J) | 59 (A B C D) | 72 (F G H J) |
| 8 (F G H J)  | 21 (A B C D) | 34 (F G H J) | 47 (A B C D) | 60 (F G H J) | 73 (A B C D) |
| 9 (A B C D)  | 22 (F G H J) | 35 (A B C D) | 48 (F G H J) | 61 (A B C D) | 74 (F G H J) |
| 10 (F G H J) | 23 (A B C D) | 36 (F G H J) | 49 (A B C D) | 62 (F G H J) | 75 (A B C D) |
| 11 (A B C D) | 24 (F G H J) | 37 (A B C D) | 50 (F G H J) | 63 (A B C D) |              |
| 12 (F G H J) | 25 (A B C D) | 38 (F G H J) | 51 (A B C D) | 64 (F G H J) |              |
| 13 (A B C D) | 26 (F G H J) | 39 (A B C D) | 52 (F G H J) | 65 (A B C D) |              |

**TEST 2**

- |                |                |                |                |                |                |
|----------------|----------------|----------------|----------------|----------------|----------------|
| 1 (A B C D E)  | 11 (A B C D E) | 21 (A B C D E) | 31 (A B C D E) | 41 (A B C D E) | 51 (A B C D E) |
| 2 (F G H J K)  | 12 (F G H J K) | 22 (F G H J K) | 32 (F G H J K) | 42 (F G H J K) | 52 (F G H J K) |
| 3 (A B C D E)  | 13 (A B C D E) | 23 (A B C D E) | 33 (A B C D E) | 43 (A B C D E) | 53 (A B C D E) |
| 4 (F G H J K)  | 14 (F G H J K) | 24 (F G H J K) | 34 (F G H J K) | 44 (F G H J K) | 54 (F G H J K) |
| 5 (A B C D E)  | 15 (A B C D E) | 25 (A B C D E) | 35 (A B C D E) | 45 (A B C D E) | 55 (A B C D E) |
| 6 (F G H J K)  | 16 (F G H J K) | 26 (F G H J K) | 36 (F G H J K) | 46 (F G H J K) | 56 (F G H J K) |
| 7 (A B C D E)  | 17 (A B C D E) | 27 (A B C D E) | 37 (A B C D E) | 47 (A B C D E) | 57 (A B C D E) |
| 8 (F G H J K)  | 18 (F G H J K) | 28 (F G H J K) | 38 (F G H J K) | 48 (F G H J K) | 58 (F G H J K) |
| 9 (A B C D E)  | 19 (A B C D E) | 29 (A B C D E) | 39 (A B C D E) | 49 (A B C D E) | 59 (A B C D E) |
| 10 (F G H J K) | 20 (F G H J K) | 30 (F G H J K) | 40 (F G H J K) | 50 (F G H J K) | 60 (F G H J K) |

**TEST 3**

- |             |              |              |              |              |              |
|-------------|--------------|--------------|--------------|--------------|--------------|
| 1 (A B C D) | 8 (F G H J)  | 15 (A B C D) | 22 (F G H J) | 29 (A B C D) | 36 (F G H J) |
| 2 (F G H J) | 9 (A B C D)  | 16 (F G H J) | 23 (A B C D) | 30 (F G H J) | 37 (A B C D) |
| 3 (A B C D) | 10 (F G H J) | 17 (A B C D) | 24 (F G H J) | 31 (A B C D) | 38 (F G H J) |
| 4 (F G H J) | 11 (A B C D) | 18 (F G H J) | 25 (A B C D) | 32 (F G H J) | 39 (A B C D) |
| 5 (A B C D) | 12 (F G H J) | 19 (A B C D) | 26 (F G H J) | 33 (A B C D) | 40 (F G H J) |
| 6 (F G H J) | 13 (A B C D) | 20 (F G H J) | 27 (A B C D) | 34 (F G H J) |              |
| 7 (A B C D) | 14 (F G H J) | 21 (A B C D) | 28 (F G H J) | 35 (A B C D) |              |

**TEST 4**

- |             |              |              |              |              |              |
|-------------|--------------|--------------|--------------|--------------|--------------|
| 1 (A B C D) | 8 (F G H J)  | 15 (A B C D) | 22 (F G H J) | 29 (A B C D) | 36 (F G H J) |
| 2 (F G H J) | 9 (A B C D)  | 16 (F G H J) | 23 (A B C D) | 30 (F G H J) | 37 (A B C D) |
| 3 (A B C D) | 10 (F G H J) | 17 (A B C D) | 24 (F G H J) | 31 (A B C D) | 38 (F G H J) |
| 4 (F G H J) | 11 (A B C D) | 18 (F G H J) | 25 (A B C D) | 32 (F G H J) | 39 (A B C D) |
| 5 (A B C D) | 12 (F G H J) | 19 (A B C D) | 26 (F G H J) | 33 (A B C D) | 40 (F G H J) |
| 6 (F G H J) | 13 (A B C D) | 20 (F G H J) | 27 (A B C D) | 34 (F G H J) |              |
| 7 (A B C D) | 14 (F G H J) | 21 (A B C D) | 28 (F G H J) | 35 (A B C D) |              |

**ACT STUDENT REVIEW:** The test administrator will give you instructions for completing this section.



**Student Review:** Your responses to these items will assist ACT and your test center in providing the best possible conditions for testing and planning for the future. Fill in the oval indicating your response to each item printed on the back of your test booklet.

- | Yes                     | No                    | Yes                      | No                    | Yes                      | No                    |
|-------------------------|-----------------------|--------------------------|-----------------------|--------------------------|-----------------------|
| 1 <input type="radio"/> | <input type="radio"/> | 6 <input type="radio"/>  | <input type="radio"/> | 11 <input type="radio"/> | <input type="radio"/> |
| 2 <input type="radio"/> | <input type="radio"/> | 7 <input type="radio"/>  | <input type="radio"/> | 12 <input type="radio"/> | <input type="radio"/> |
| 3 <input type="radio"/> | <input type="radio"/> | 8 <input type="radio"/>  | <input type="radio"/> | 13 <input type="radio"/> | <input type="radio"/> |
| 4 <input type="radio"/> | <input type="radio"/> | 9 <input type="radio"/>  | <input type="radio"/> | 14 <input type="radio"/> | <input type="radio"/> |
| 5 <input type="radio"/> | <input type="radio"/> | 10 <input type="radio"/> | <input type="radio"/> | 15 <input type="radio"/> | <input type="radio"/> |



# Form Z18

(April 2023)



The **ACT**<sup>®</sup>

2022 | 2023

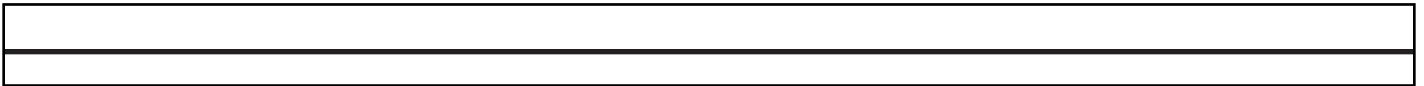

In response to your request for Test Information Release materials, this booklet contains the test questions, scoring keys, and conversion tables used in determining your ACT scores. Enclosed with this booklet is a report that lists each of your answers, shows whether your answer was correct, and, if your answer was not correct, gives the correct answer.

**~~ACT owns the test questions and responses, and you may not share them with anyone in any form.~~**





## ENGLISH TEST

45 Minutes—75 Questions

**DIRECTIONS:** In the five passages that follow, certain words and phrases are underlined and numbered. In the right-hand column, you will find alternatives for the underlined part. In most cases, you are to choose the one that best expresses the idea, makes the statement appropriate for standard written English, or is worded most consistently with the style and tone of the passage as a whole. If you think the original version is best, choose “NO CHANGE.” In some cases, you will find in the right-hand column a question about the underlined part. You are to choose the best answer to the question.

You will also find questions about a section of the passage, or about the passage as a whole. These questions do not refer to an underlined portion of the passage, but rather are identified by a number or numbers in a box.

For each question, choose the alternative you consider best and fill in the corresponding oval on your answer document. Read each passage through once before you begin to answer the questions that accompany it. For many of the questions, you must read several sentences beyond the question to determine the answer. Be sure that you have read far enough ahead each time you choose an alternative.

## PASSAGE I

## Life in the Forest Canopy

For more than thirty-five years,

Dr. Nalini Nadkarni’s study of tree canopies,  
1

the layer of branches between the forest floor and the sky,  
2  
in rain forests in Washington State and Costa Rica. Early  
in her career, she became particularly interested in one

type of plant: epiphytes. These plants grow on other plants,  
3

such as trees, and more than 28,000 species of epiphytes  
4  
exist worldwide. Instead, their leaves absorb dissolved  
4  
nutrients from mists and fogs. Nadkarni found that the  
epiphyte nutrients made up about half the nutrients in the

tree foliage of tropical cloud forests; however, almost no  
5  
one had studied them. She decided to focus on the effects  
epiphytes have on the canopy and the forest.

www.actexam.net

1. A. NO CHANGE  
B. Nadkarni, a scientist studying  
C. Nadkarni has studied  
D. Nadkarni, studying
2. If the writer were to delete the underlined portion (adjusting the punctuation as needed), the essay would primarily lose information that:  
F. clarifies that Nadkarni is an experienced tree-canopy researcher.  
G. conveys that tree canopies are relatively difficult for scientists to access.  
H. provides a definition of tree canopies.  
J. defines what constitutes a rain forest.
3. A. NO CHANGE  
B. plant: which are  
C. plant;  
D. plant
4. Given that all the choices are accurate, which one provides the best transition to the next sentence?  
F. NO CHANGE  
G. and mosses and orchids are examples of common epiphytic plants.  
H. where they thrive despite the inhospitable conditions of the canopy.  
J. but they do not rely on their hosts for food.
5. A. NO CHANGE  
B. for example,  
C. therefore,  
D. in short,



Nadkarni's research has answered many questions about rain forest epiphytes. For example, Nadkarni wondered how epiphytes could grow on tree branches hundreds of feet above the ground. Where did they get their soil? She discovered that epiphytic mosses grow in soil that they generate for itself. After they die, the mosses decompose in place, becoming a layer of soil called crown humus, which can be up to ten inches thick. This organic material, rich in nutrients, supports epiphyte growth.

Nadkarni also helped explain how rain forest trees flourish despite growing where frequent rains wash nutrients out of their soil. Peeling back the moss on a branch, Nadkarni found roots that grew out of the tree branch and into the crown humus. The trees had developed roots to take in nutrients from the soil created by epiphytes on the trees' branches. Epiphytes, in exchange for a place in the canopy, helps feed the trees on which they grow.

The trees get nutrients from the crown humus.

Over the course of her career, Nadkarni has published three books and more than ninety-five

research papers. Rather, she also cofounded the International Canopy Network, which spreads information about tree canopies through the media.

6. F. NO CHANGE  
G. themselves.  
H. by itself.  
J. itself.

7. A. NO CHANGE  
B. on the branch were  
C. the tree had  
D. there were

8. F. NO CHANGE  
G. Epiphytes, in exchange,  
H. Epiphytes in exchange,  
J. Epiphytes in exchange

9. A. NO CHANGE  
B. is helping to feed  
C. help feed  
D. feeds

10. F. NO CHANGE  
G. They live on branches far away from the ground.  
H. Epiphytes actually generate their own soil.  
J. DELETE the underlined portion.

11. A. NO CHANGE  
B. published: three books,  
C. published three books,  
D. published, three books

12. F. NO CHANGE  
G. In other words, she  
H. For instance, she  
J. She



Her work has demonstrated the critical role that

13

rain forest tree canopies achieve in rain forest ecosystems.

14

13. Which choice most clearly conveys that Nadkarni's research is ongoing?

- A. NO CHANGE
- B. is known for showing
- C. continues to uncover
- D. brought attention to

14. F. NO CHANGE

- G. tree canopies, which Nadkarni studies, play
- H. makes tree canopies crucially important
- J. tree canopies play

Question 15 asks about the preceding passage as a whole.

15. Suppose the writer's primary purpose had been to discuss one scientist's contributions to a particular field. Would this essay accomplish that purpose?

- A. Yes, because it focuses on how Nadkarni first became interested in studying epiphytes.
- B. Yes, because it focuses on Nadkarni's research into epiphytes and rain forest canopies.
- C. No, because it primarily describes how epiphytes in the canopy create crown humus.
- D. No, because it primarily discusses how Nadkarni's hypotheses differed from her actual findings.

## PASSAGE II

### Alicia Alonso Steps Up

[1]

[A] Late in October 1943, New York City's American Ballet Theatre being just days away from the opening night of *Giselle*. The company's prima ballerina, or leading female dancer, had suddenly become too ill to perform. [B] At once, the company's other dancers were asked whether they could perform the title role.

16

17

16. F. NO CHANGE

- G. Theatre, which was
- H. Theatre was
- J. Theatre,

17. Which choice most clearly indicates that the dancers were approached individually about performing the title role?

- A. NO CHANGE
- B. One by one,
- C. Meanwhile,
- D. One time,



With so little time to learn the part, all refused—all  
<sup>18</sup>  
except Alicia Alonso.

[2]

Seizing the opportunity she had dreamed of since childhood, Alonso debuted as Giselle on November 2, her performance earning wide acclaim. [C] Alonso, who  
<sup>19</sup>  
went on to dance the role for another five years, was soon promoted to principal dancer. One of the highest-ranked  
<sup>20</sup>  
positions in a ballet company. 21

[3]

This rise to prominence was a big to-do because,  
<sup>22</sup>  
for more than a year prior to her breakout performance as Giselle, Alonso had been confined to bed. After three eye surgeries to repair a detached retina, she was instructed to remain still, not allowed to move her head, let alone dance.  
<sup>23</sup>  
However, Alonso's belief that dancers must exercise not only the body but also the mind led her to rehearse  
<sup>24</sup>  
mentally. Lying motionless, she repeatedly envisioned the steps and movements of classical ballets. By the time she had fully recovered, Alonso knew *Giselle* by heart. [D]

18. If the writer were to delete the underlined portion (adjusting the capitalization as needed), the paragraph would primarily lose a detail that:
- F. indicates the amount of time a dancer spends onstage when performing a major role.
  - G. helps explain why most of the dancers declined to perform the role of Giselle.
  - H. demonstrates the rarity of finding dancers of a caliber high enough to perform well in major roles.
  - J. helps illustrate how the company's prima ballerina had memorized the role of Giselle.
19. A. NO CHANGE  
B. who had  
C. whom  
D. which
20. F. NO CHANGE  
G. dancer; which is one  
H. dancer—one  
J. dancer one
21. At this point, the writer is considering adding the following true sentence:
- Prima ballerina assoluta*, an honorific rarely bestowed, is used to recognize only the most exceptional dancers in a generation.
- Should the writer make this addition here?
- A. Yes, because it indicates that Alonso would go on to earn the title of *prima ballerina assoluta*.
  - B. Yes, because it introduces the highest accolade to which a female ballet dancer can aspire.
  - C. No, because it detracts from the paragraph's focus on Alonso's success in performing *Giselle*.
  - D. No, because it repeats information mentioned earlier in the essay.
22. F. NO CHANGE  
G. all the more notable  
H. super noteworthy  
J. that much cooler
23. A. NO CHANGE  
B. still, she was not  
C. still. Not being  
D. still; not
24. F. NO CHANGE  
G. in addition to  
H. as well as  
J. also



[4]

Despite a flourishing dance career, by 1948, Alonso felt compelled to return to her native Cuba to establish a ballet school. At the time, Cuba had few national interest in ballet and fewer ballet schools.  
25

Now, decades later, Alonso's Ballet Nacional de Cuba is recognized as one of the world's foremost ballet companies, it has served as the training grounds  
26  
27

for generations of world-class dancers. Unless most professional ballet dancers retire around age 35, Alonso performed as a principal dancer with the company well into her seventies. Even into her nineties, the prima ballerina has continued to choreograph, saying, "I felt completely identified with Giselle."  
28  
29

25. A. NO CHANGE  
B. little national interest in ballet and few  
C. fewer national interest in ballet and less  
D. little national interest in ballet and less
26. F. NO CHANGE  
G. In essence,  
H. Therefore,  
J. Soon,
27. A. NO CHANGE  
B. her school  
C. having  
D. DELETE the underlined portion.
28. F. NO CHANGE  
G. By the time  
H. As long as  
J. Whereas
29. Given that all the choices are quotations from Alonso, which one best concludes the paragraph and the essay?  
A. NO CHANGE  
B. "Cubanness is not a single thing but many; it is something alive and difficult to capture."  
C. "When I was little, I'd move around whenever I heard music."  
D. "Dance, to me, is life itself."

Question 30 asks about the preceding passage as a whole.

30. The writer is considering adding the following sentence to the essay:
- Tickets were already sold out; management was desperate to replace the show's star.
- If the writer were to add the sentence, it would most logically be placed at:
- F. Point A in Paragraph 1.  
G. Point B in Paragraph 1.  
H. Point C in Paragraph 2.  
J. Point D in Paragraph 3.





## PASSAGE III

## Reading an Unearthed Past

In 1973, archaeologist, Robin Birley,<sup>31</sup>

discovery of a lifetime,<sup>32</sup> it's a thin piece of wood the size of a postcard. This unremarkable-looking object was, in fact, ancient correspondence dating to roughly AD 100.

Discovered at the ruins of the Roman fort Vindolanda in northern Britain,<sup>33</sup> this artifact had been sent to a soldier,

along with sandals, socks, and underclothes. Just one<sup>34</sup>

of many such wooden documents found at the site.<sup>35</sup>

Known as the Vindolanda tablets, the fort is home to<sup>36</sup> Britain's earliest handwritten documents. To date,<sup>36</sup>

over one thousand tablets<sup>37</sup> have been discovered.

Still, the<sup>38</sup> abundance of preserved tablets

is<sup>39</sup> mainly due to building practices at the fort.

31. A. NO CHANGE  
 B. archaeologist Robin Birley  
 C. archaeologist, Robin Birley  
 D. archaeologist Robin Birley,
32. F. NO CHANGE  
 G. lifetime:  
 H. lifetime;  
 J. lifetime
33. If the writer were to delete the underlined portion (adjusting the punctuation as needed), the essay would primarily lose a detail that:  
 A. emphasizes the importance of Vindolanda compared to other Roman forts.  
 B. explains why articles of clothing would have been sent with correspondence.  
 C. clarifies the geographical location of the Vindolanda fort.  
 D. indicates the geographical location of the artifact's sender.
34. F. NO CHANGE  
 G. This was just one  
 H. Which was one  
 J. One
35. A. NO CHANGE  
 B. founded at the cite.  
 C. founded at the site.  
 D. found at the cite.
36. F. NO CHANGE  
 G. among the fort's treasures are the earliest handwritten documents ever found in Britain.  
 H. researchers unearthed the earliest handwritten documents ever found in Britain.  
 J. these are the earliest handwritten documents ever found in Britain.
37. A. NO CHANGE  
 B. tablets that turned out to be ancient correspondence  
 C. wooden documents known as tablets  
 D. tablets as of now
38. F. NO CHANGE  
 G. Consequently, the  
 H. For example, the  
 J. The
39. A. NO CHANGE  
 B. have been  
 C. were  
 D. are



After demolishing obsolete structures, so Roman soldiers buried the ruins with soil and turf. Layers of clay combined with a wet environment that was free of the oxidizing affects with air resulted in conditions perfect for preserving organic artifacts for almost two thousand years.

While maintaining these ideal conditions when an artifact is excavated is essential. Bacteria, fungus, and oxidation can destroy a fragile tablet once it is unearthed. Therefore, when a tablet is found, researchers take measures to prevent it from drying out. After an excavated tablet has been removed from the fort, experts use ether and methyl alcohol to preserve it. As a final step before the preserved tablet goes into permanent, climate-controlled storage, infrared photography is employed to render the ink writing more visible, allowing researchers to determine how the tablet was used.

More than just ancient objects, the tablets provide rare historical insights about the people who lived and worked at Vindolanda. The correspondents were people from all over the fort. Some tablets held supply orders or inventories; some contained family letters; some featured student writing. As windows to the past, these artifacts reveal

that all people should be able to express themselves.

40. F. NO CHANGE  
G. therefore  
H. then  
J. DELETE the underlined portion.
41. A. NO CHANGE  
B. effects with  
C. effects of  
D. affects of
42. F. NO CHANGE  
G. Whereas maintaining  
H. As maintaining  
J. Maintaining
43. A. NO CHANGE  
B. doing what is inevitable in the open air, which is drying out.  
C. drying out after it has been discovered.  
D. losing all moisture and drying out.
44. Given that all the choices are accurate, which one offers specific information that most effectively conveys the variety of perspectives found in the Vindolanda tablets?  
F. NO CHANGE  
G. students and soldiers, officers and their wives, merchants and their customers.  
H. not only soldiers but other people who lived at the fort as well.  
J. people of different backgrounds.
45. Which of the following choices would most effectively conclude the paragraph and the essay?  
A. NO CHANGE  
B. that we don't always know as much about history as we think we do.  
C. a world that otherwise would have remained buried and forgotten.  
D. many useful examples of ancient Latin cursive writing.

## PASSAGE IV

## Twelve Thousand Pieces of House

Two days after my family moved into a bigger house in a different neighborhood of San Diego, our neighbor Mr. Vega visited us and came to welcome us. He had lived

on this street his entire life: all eighty-plus years of it—and he not only remembered when our house was built but also helped build it. “We made it from a kit,” he said.

I assumed he was joking, but he launched into the story. The summer he was sixteen, the two brothers who had bought this plot of land hired him

as a helper. First they drove to the railroad depot, once they arrived a freight car sat stuffed with lumber, boxes, and bundles. These were the twelve thousand pieces of their house kit, everything from rafters and shingles plus doorknobs and nails. Simply transporting the materials to the building site took six trips in the brothers’ large truck.

With the kit came an instruction book, one containing enough detail, which a person with basic carpentry skills,

a relative set of tools, and a willingness to sweat could construct a sturdy and attractive house. Each piece of lumber bore a number, and the instructions specified where each one went. As Mr. Vega and the brothers worked day by day, the house rose up piece by piece.

46. F. NO CHANGE  
G. Vega came to welcome us a couple days after we’d moved.  
H. Vega, who lived nearby, came to welcome us.  
J. Vega came to welcome us.

47. A. NO CHANGE  
B. life—  
C. life;  
D. life

48. F. NO CHANGE  
G. brothers—who had bought this plot of land—  
H. brothers, who had bought this plot of land,  
J. brothers who had bought this plot of land,

49. A. NO CHANGE  
B. where  
C. there  
D. DELETE the underlined portion.

50. F. NO CHANGE  
G. as well as  
H. with  
J. to

51. A. NO CHANGE  
B. detail, where  
C. detail that  
D. detail for

52. F. NO CHANGE  
G. restrained  
H. habitual  
J. modest

53. The writer would like this part of the sentence to mirror the pattern of the first part of the sentence. Which choice best accomplishes that goal?  
A. NO CHANGE  
B. progressed closer toward completion.  
C. grew larger with each board and nail.  
D. took shape, rising from the ground.

They did experience momentous fearfulness when  
<sup>54</sup>  
 the instruction book blew away one afternoon. After  
 a two-hour search, Mr. Vega finally discovered that a  
 neighborhood dog had carried the book under a porch.  
 Overall, it took seven weeks to finish the house.

Back then, Mr. Vega claimed, kit  
<sup>55</sup>  
houses weren't uncommon. He pointed  
<sup>55</sup>

out that two more kit-built houses across the  
<sup>56</sup>  
 street. Part of the appeal of building a house

from a kit came from the fact that you could  
<sup>57</sup>  
 build one for less than what a professional  
 builder would charge.

Placed near the end of each beam, Mr. Vega  
<sup>58</sup>  
 showed us the kit's numbers stamped on the wooden  
 beams in the basement. Then he pointed to the underside  
 of a floorboard scratched into the wood, faint but legible,  
<sup>59</sup>  
 was "Cedro Vega, 1947."

54. F. NO CHANGE  
 G. face an insidious terror  
 H. have a scare  
 J. flip way out

55. Which choice best introduces this paragraph?  
 A. NO CHANGE  
 B. Mr. Vega said the experience he gained building the house helped him get a carpentry job later.  
 C. After the completion of the house, Mr. Vega had one week until school started.  
 D. Mr. Vega had seen many changes in the neighborhood over time.

56. F. NO CHANGE  
 G. to where  
 H. how  
 J. out

57. A. NO CHANGE  
 B. arose through  
 C. stemmed to  
 D. resulted by

58. F. NO CHANGE  
 G. After finishing his story,  
 H. Each five digits long,  
 J. Easily readable,

59. A. NO CHANGE  
 B. floorboard and scratched  
 C. floorboard. Scratched  
 D. floorboard, scratched

Question 60 asks about the preceding passage as a whole.

60. Suppose the writer's primary purpose had been to examine the history of kit houses in the United States. Would this essay accomplish that purpose?  
 F. Yes, because the essay outlines the rise of the kit house industry and its impact in the twentieth century.  
 G. Yes, because the essay centers on Mr. Vega's knowledge of how kit houses became popular.  
 H. No, because the essay explains why kit houses eventually lost popularity in the United States.  
 J. No, because the essay focuses on Mr. Vega's personal experience building one kit house.



## PASSAGE V

## Small Wonders

At first glance, the tiny scenes may not attract a passerby's attention. Miniature toys, seemingly abandoned by a child, are arranged on sidewalks and in alleyways, at risk of being stepped on or swept away by rain. A closer look, however, reveals that these plastic figurines have been strategically placed and, though inanimate, appear to be busying themselves. In Paris, for instance, near a street café's outdoor trash can, a tiny waiter <sup>61</sup> holding a menu prepares to seat customers who are waiting behind a velvet rope. A pastry and

its crumpled wrapper, discarded by a café patron, <sup>62</sup>

serve as the backdrop, a reminder of the real-world <sup>63</sup> setting.

Nevertheless, such scenes are painstakingly created <sup>64</sup>

and photographed by London-based artist Slinkachu. <sup>65</sup> Working exclusively in urban areas, he uses figurines from toy train sets to create small scenes in a big world.

61. If the writer were to delete the underlined portion, the sentence would primarily lose:
- A. information pinpointing the street on which the scene being described is located.
  - B. a detail explaining why the scene's creator favors particular outdoor locales when staging scenes.
  - C. an example of an object that the essay indicates is often featured in the artworks of the scene's creator.
  - D. a detail that helps clarify the setting of the scene being described.
62. F. NO CHANGE  
 G. it's crumpled wrapper, discarded by  
 H. its crumpled wrapper, discarded amid  
 J. it's crumpled wrapper, discarded to
63. A. NO CHANGE  
 B. which serve  
 C. serve  
 D. DELETE the underlined portion.
64. F. NO CHANGE  
 G. In addition, such  
 H. As a result, such  
 J. Such
65. A. NO CHANGE  
 B. by London-based artist—  
 C. by, London-based artist,  
 D. by: London-based artist



After crafting intricate props such as<sup>66</sup>—a waterslide made from a painted and coiled garden hose or a basketball hoop made from a soda can pop-top—Slinkachu spends hours carefully staging a scene. He photographs it up close, and then shoots (from farther and farther back),<sup>67</sup>

until he captures the larger cityscape,<sup>68</sup> the tiny scene nearly vanishing from view. Once the artist has finished his shots, he simply walks away.

Slinkachu likens his miniature scenes, which are quite small,<sup>69</sup> to obscure

treasures. Some are praised tremendously<sup>70</sup> by

pedestrians. Others are<sup>71</sup> carried away by wind or rain, may never be seen at all. Due to the temporary nature of Slinkachu's works, his photographs, rather than actual scenes, are displayed in art galleries.

66. F. NO CHANGE  
 G. props—such as  
 H. props, such as,  
 J. props such as:
67. A. NO CHANGE  
 B. close and then shoots from farther and farther back  
 C. close (and then shoots, from farther and farther back)  
 D. close, and then, shoots from farther and farther back,
68. F. NO CHANGE  
 G. metropolitan setting surrounding the little scene,  
 H. city itself on a greater scale,  
 J. urban city metropolis,
69. A. NO CHANGE  
 B. scenes, which he photographs extensively,  
 C. scenes, painstakingly crafted and staged,  
 D. scenes
70. Which choice most clearly indicates that people have kept pieces from some of Slinkachu's scenes?  
 F. NO CHANGE  
 G. spotted and collected  
 H. examined thoroughly  
 J. noticed and appreciated
71. A. NO CHANGE  
 B. Others, they are  
 C. Others could be  
 D. Others,



[1] Slinkachu’s art often highlights how small and lonely one can feel in a busy urban center. [2] Standing next to a lone palm tree, the pair looks out for rescue.

[3] One London scene, arranged in a rain puddle on an asphalt path, features a minuscule couple stranded atop a tennis-ball island. [4] This work, like many others in Slinkachu’s portfolio, conveys a notable

72

message, moments of drama (and even humor) can

73

be found everywhere, if you take the time to look. 74

72. F. NO CHANGE  
 G. have conveyed  
 H. are conveying  
 J. convey

73. A. NO CHANGE  
 B. message and his art reminds us that  
 C. message, he suggests that  
 D. message:

74. For the sake of the logic and cohesion of this paragraph, Sentence 2 should be placed:  
 F. where it is now.  
 G. before Sentence 1.  
 H. after Sentence 3.  
 J. after Sentence 4.

Question 75 asks about the preceding passage as a whole.

75. Suppose the writer’s primary purpose had been to discuss the impact one artist’s creative process has had on the art world. Would this essay accomplish that purpose?  
 A. Yes, because it explains how Slinkachu has inspired a new trend in the way urban art is produced.  
 B. Yes, because it describes in detail the steps in Slinkachu’s creative process.  
 C. No, because it instead provides an overview of Slinkachu’s particular style and methods.  
 D. No, because it instead focuses on the rise in popularity of urban art, using Slinkachu’s work as an example.

**END OF TEST 1**

**STOP! DO NOT TURN THE PAGE UNTIL TOLD TO DO SO.**

**MATHEMATICS TEST**

60 Minutes—60 Questions

**DIRECTIONS:** Solve each problem, choose the correct answer, and then fill in the corresponding oval on your answer document.

Do not linger over problems that take too much time. Solve as many as you can; then return to the others in the time you have left for this test.

You are permitted to use a calculator on this test. You may use your calculator for any problems you choose,

but some of the problems may best be done without using a calculator.

Note: Unless otherwise stated, all of the following should be assumed.

1. Illustrative figures are NOT necessarily drawn to scale.
2. Geometric figures lie in a plane.
3. The word *line* indicates a straight line.
4. The word *average* indicates arithmetic mean.

1. A manufacturing assembly line packages 26 cases of cottage cheese per minute. How many cases of cottage cheese does the assembly line package in 7 hours ?

- A. 90
- B. 182
- C. 223
- D. 5,349
- E. 10,920

2. In the figure below,  $C$  is the intersection of  $\overline{AD}$  and  $\overline{BE}$ . What is the measure of  $\angle BAC$  ?

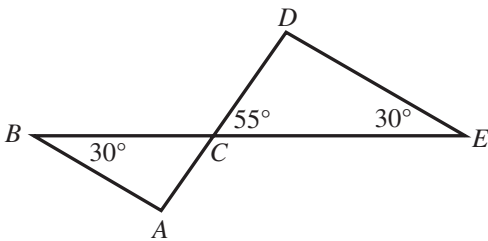

- F.  $85^\circ$
- G.  $95^\circ$
- H.  $115^\circ$
- J.  $120^\circ$
- K.  $140^\circ$

3. If  $11 + 4c = 31$ , then  $3c = ?$

- A. 5
- B. 15
- C. 16
- D. 19
- E.  $\frac{63}{2}$

www.actexam.net

**DO YOUR FIGURING HERE.**





4. What is the least common denominator of the 3 fractions  $\frac{2}{15}$ ,  $\frac{5}{6}$ , and  $\frac{7}{8}$ ?

F. 6  
 G. 8  
 H. 15  
 J. 90  
 K. 120

5. For  $\overleftrightarrow{RT}$  shown below, point  $S$  is on  $\overline{RT}$ , the length of  $\overline{RS}$  is 10 cm, and the length of  $\overline{ST}$  is 22 cm. What is the distance, in centimeters, between  $T$  and the midpoint of  $\overline{RS}$ ?



- A. 16  
 B. 21  
 C. 22  
 D. 27  
 E. 32
6. Three friends are picking apples. Bill picks 5 red and 3 green apples; Ming picks 8 red and 2 green apples; Randi picks 2 red and 4 green apples. They combine their apples into an empty basket. Ming will randomly select 1 apple from the basket. What is the probability she will select a green apple?

F.  $\frac{1}{5}$   
 G.  $\frac{3}{8}$   
 H.  $\frac{1}{2}$   
 J.  $\frac{3}{5}$   
 K.  $\frac{5}{8}$

7. The students in Mr. Montag's literature class are playing review games. For prizes, Mr. Montag has a bag that initially contained 23 fruit bars of different flavors: 6 cherry, 5 blueberry, 4 strawberry, and 8 raspberry. No fruit bars are added to the bag during the class. After each game, the winner randomly selects 1 fruit bar from the bag to keep. The winners of the first 4 games selected 1 cherry, 1 strawberry, and 2 raspberry fruit bars. Lin wins the 5th game. What is the probability that Lin will select a raspberry fruit bar?

A.  $\frac{6}{23}$   
 B.  $\frac{6}{19}$   
 C.  $\frac{8}{23}$   
 D.  $\frac{7}{19}$   
 E.  $\frac{8}{19}$

**DO YOUR FIGURING HERE.**



8. If  $x + \frac{2}{5} = \frac{3}{25}$ , then  $x = ?$

F.  $\frac{10}{3}$

G.  $\frac{13}{25}$

H.  $\frac{3}{10}$

J.  $\frac{1}{20}$

K.  $-\frac{7}{25}$

**DO YOUR FIGURING HERE.**

9. In the standard  $(x,y)$  coordinate plane, what is the slope of the line  $7x + 4y = 8$  ?

A.  $-7$

B.  $-\frac{7}{4}$

C.  $\frac{7}{8}$

D.  $7$

E.  $8$

10. The expression  $(6c - 3d)(3c + d)$  is equivalent to:

F.  $18c^2 - 15cd - 3d^2$

G.  $18c^2 - 15cd + 3d^2$

H.  $18c^2 - 3cd - 3d^2$

J.  $18c^2 - 3cd + 3d^2$

K.  $18c^2 - 3d^2$

11. How many *minutes* would it take a train to travel 100 miles at a constant speed of 120 miles per hour?

(Note: There are 60 minutes in 1 hour.)

A. 20

B. 50

C. 72

D. 83

E. 120

12. A quilt maker uses \$25 worth of materials to produce a single quilt that sells for \$100. What is the minimum number of this type of quilt the quilt maker can produce and sell to earn a profit of at least \$900 ?

F. 8

G. 9

H. 12

J. 27

K. 36



13. What is the volume, in cubic inches, of a cylinder that has a diameter of 16 inches and a height of 25 inches?

(Note: The volume,  $V$ , of a cylinder with radius  $r$  and height  $h$  is given by  $V = \pi r^2 h$ .)

- A.  $200\pi$   
 B.  $400\pi$   
 C.  $1,600\pi$   
 D.  $5,000\pi$   
 E.  $6,400\pi$
14. The lengths of corresponding sides of 2 similar right triangles are in the ratio 2:7. The hypotenuse of the smaller triangle is 8 inches long. How many inches long is the hypotenuse of the larger triangle?
- F. 3.5  
 G. 9  
 H. 13  
 J. 14  
 K. 28
15. The Student Council is preparing a budget for an upcoming fund-raising dance. They have decided to spend \$225 for a light and sound show, \$600 for refreshments, and \$75 for decorations. These are the only expenses. Given that the Student Council estimates 400 students will attend the dance, what should be the price, per student, for admission to the dance if the Student Council wants to raise as close as possible to \$500 after paying expenses?
- A. \$0.80  
 B. \$1.25  
 C. \$1.60  
 D. \$2.25  
 E. \$3.50
16. In kite  $ABCD$ , shown below, the diagonals intersect at  $E$  at a right angle. The given lengths are in centimeters. Which of the following values is closest to the perimeter, in centimeters, of  $ABCD$  ?

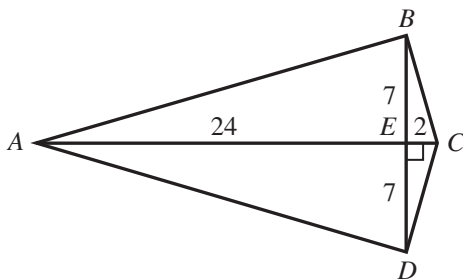

- F. 32  
 G. 40  
 H. 65  
 J. 91  
 K. 182

www.crackab.com

DO YOUR FIGURING HERE.

GO ON TO THE NEXT PAGE.



17. In the standard  $(x,y)$  coordinate plane below, point  $C$  has coordinates  $(7,5)$ , and the midpoint of  $\overline{AC}$  is point  $B$ , which has coordinates  $(-\frac{3}{2}, 1)$ . What are the coordinates of point  $A$ ?

A.  $(-10, -3)$

B.  $(-4, 7)$

C.  $(-\frac{17}{2}, 4)$

D.  $(\frac{11}{2}, 6)$

E.  $(\frac{11}{4}, 3)$

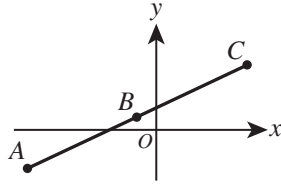

**DO YOUR FIGURING HERE.**

18. The price of 4 meals for Erin and her 3 friends was \$60 before the addition of tax and tip. Erin and 2 friends each had meals of equal price. The price of the 3rd friend's meal was twice the price of Erin's meal. What was the price, in dollars, of Erin's meal?

F. \$10

G. \$12

H. \$15

J. \$20

K. \$30

19. Camp counselors will combine  $5\frac{1}{2}$  pounds of peanuts with  $1\frac{1}{4}$  pounds of cashews to make trail mix for their campers. Each camper will get a small bag filled with  $\frac{1}{8}$  pound of the trail mix. What is the maximum number of bags of trail mix that the camp counselors can fill?

A. 10

B. 34

C. 44

D. 50

E. 54

20. A student took 4 chemistry tests and earned an average score of exactly 80 points. A score of how many points on the 5th test will earn the student an average score of exactly 82 points for the 5 tests?

F. 72

G. 81

H. 82

J. 84

K. 90



21. What are the solutions to the equation  $|u - 6| = 5$  ?

- A. -1 and 1
- B. -1 and 11
- C. 1 and -11
- D. 1 and 11
- E. -11 and 11

**DO YOUR FIGURING HERE.**

22. Matrices  $A$  and  $B$  are given below.

$$A = \begin{bmatrix} 2 & -6 \\ -3 & 8 \end{bmatrix} \quad B = \begin{bmatrix} -8 & 5 \\ 3 & 4 \end{bmatrix}$$

Which of the following matrices is  $A - B$  ?

- F.  $\begin{bmatrix} -10 & 11 \\ 6 & -4 \end{bmatrix}$
- G.  $\begin{bmatrix} -6 & 0 \\ -1 & 12 \end{bmatrix}$
- H.  $\begin{bmatrix} -6 & -1 \\ 0 & 12 \end{bmatrix}$
- J.  $\begin{bmatrix} 10 & -6 \\ -11 & 4 \end{bmatrix}$
- K.  $\begin{bmatrix} 10 & -11 \\ -6 & 4 \end{bmatrix}$

23. For all positive real numbers  $a$ ,  $(\sqrt[3]{a^{36}})^{\frac{1}{2}} = ?$

- A.  $a^3$
- B.  $a^6$
- C.  $a^{15}$
- D.  $a^{30}$
- E.  $a^{54}$

24. For what value of  $x$  is the function below undefined?

$$f(x) = \frac{2(x+3)}{(x+3)}$$

- F. -3
- G. 0
- H. 1
- J. 2
- K. 3

25. A bag contains 8 red marbles, 5 yellow marbles, and 7 green marbles. How many additional red marbles must be added to the 20 marbles already in the bag so that the probability of randomly drawing a red marble is  $\frac{3}{5}$  ?

- A. 5
- B. 10
- C. 18
- D. 20
- E. 24



26. One of the following graphs in the standard  $(x,y)$  coordinate plane is the graph of the equation  $3y - 2x = 6$ . Which graph?

F.

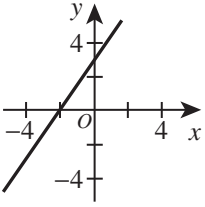

J.

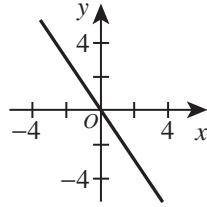

G.

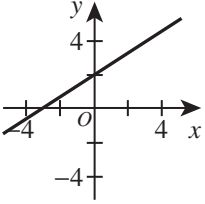

K.

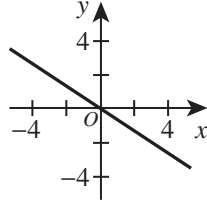

H.

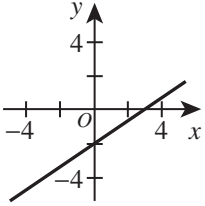

27. If an obtuse angle is bisected, the resulting angles *must*:

- A. both be acute.
- B. be complementary.
- C. both be obtuse.
- D. both be right.
- E. be supplementary.

28. What is the least positive number that has a remainder of 4 when divided by 7 and a remainder of 3 when divided by 6?

- F. 20
- G. 35
- H. 39
- J. 42
- K. 46

29. The vertices of  $\triangle PQR$  are given in the standard  $(x,y)$  coordinate plane below. What is the area, in square coordinate units, of  $\triangle PQR$ ?

- A. 6
- B. 10
- C. 12
- D. 15
- E. 30

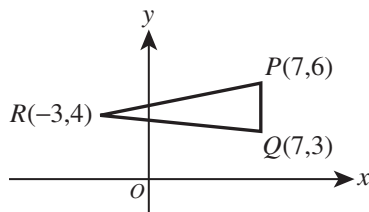

www.actexam.net

DO YOUR FIGURING HERE.



Use the following information to answer questions 30–32.

DO YOUR FIGURING HERE.

Data for each of 10 students is represented by a corresponding data point plotted in the standard  $(x,y)$  coordinate plane below. Each point has 2 integer coordinates. The  $x$ -coordinate is the number of hours the student spent studying for a retake test, and the  $y$ -coordinate is the change in score from the original test to the retake test. Noel drew the line shown through 2 data points to help predict future changes in score.

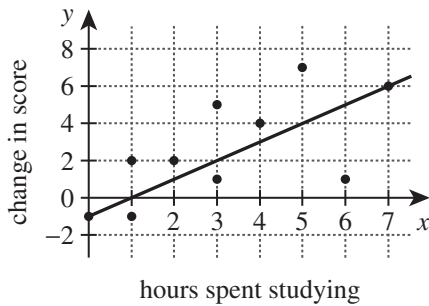

30. Both the original and the retake tests had a maximum score of 50. Among the 10 students who took the retake test, Jin studied for the greatest number of hours. What is the number of *percentage* points Jin's score increased?
- F. 7%  
 G. 12%  
 H. 13%  
 J. 16%  
 K. 30%
31. What is the median number of hours spent studying by all 10 students?
- A. 2.0  
 B. 2.5  
 C. 3.0  
 D. 3.2  
 E. 3.5
32. An 11th student is currently retaking the test. This student has studied 5 hours for the retake test. According to Noel's line, what is the predicted change in score for the 11th student?
- F. 2  
 G. 3  
 H. 4  
 J. 5  
 K. 7

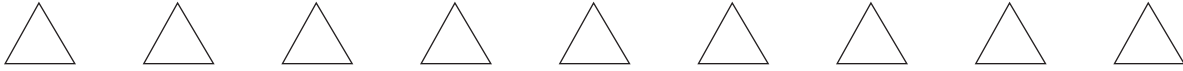

Use the following information to answer questions 33–35.

DO YOUR FIGURING HERE.

A particular brand of paper towel has 193 sheets per roll, and each sheet is 11 in by 5.5 in. The paper towels come in boxes of 6 rolls with a shipping weight of 6.8 pounds. The cost for a box of 6 rolls of this paper towel is \$15.99 plus the shipping cost, given in the table below.

Number of boxes shipped	Shipping cost per box
1–10	\$13.25
11–99	\$12.00
100 or more	\$10.00

The diameter of each cylindrical roll is 6 inches. Each roll has a cylindrical hole 1.5 inches in diameter, and each roll has a height of 11 inches, as shown in the diagrams below.

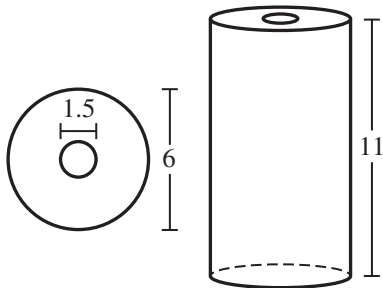

33. The 6 rolls are shipped in a box as shown below where the interior of the box is as small as possible. What are the interior dimensions of this box, in inches?

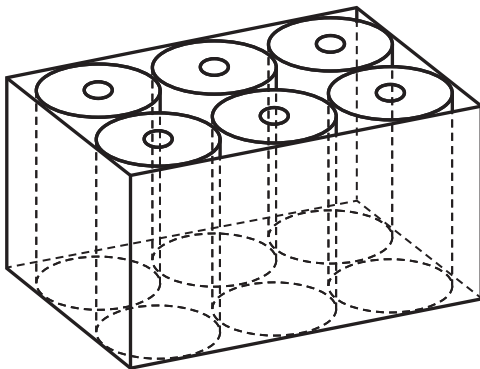

- A.  $8 \times 12 \times 11$   
 B.  $9 \times 13.5 \times 11$   
 C.  $11 \times 16.5 \times 11$   
 D.  $12 \times 18 \times 11$   
 E.  $36 \times 36 \times 66$





34. The total weight of the box and packaging material is 1 pound. Which of the following numeric expressions represents the weight, in pounds, of 1 roll of these paper towels?

F.  $\frac{6.8 - 1}{6}$

G.  $\frac{6.8}{6}$

H.  $\frac{6.8 + 1}{6}$

J.  $6(6.8)$

K.  $6(6.8 - 1)$

**DO YOUR FIGURING HERE.**

35. Assuming a use of 5 paper towel sheets per day, what is the least number of boxes of paper towels that should be ordered to ensure a 2-year supply?

- A. 1  
 B. 2  
 C. 3  
 D. 4  
 E. 5

36. On the number line below, the distance between 0 and 10 is divided into 7 segments of equal length by the points with locations  $a$  through  $f$ . Which of the following mathematical statements about  $\sqrt{10}$  is true?

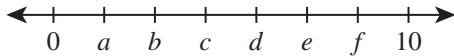

F.  $c = \sqrt{10}$

G.  $d = \sqrt{10}$

H.  $b < \sqrt{10} < c$

J.  $c < \sqrt{10} < d$

K.  $d < \sqrt{10} < e$

37. What is the solution to  $1 - \frac{2}{x} = \frac{x}{x+5}$ ?

A.  $-\frac{10}{7}$

B.  $-1$

C.  $3$

D.  $\frac{10}{3}$

E.  $4$

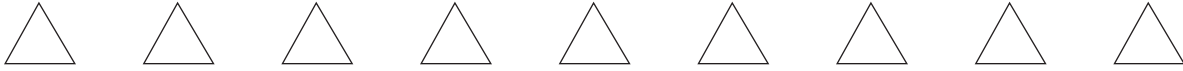

38. What time is it exactly 230 hours after 3 p.m. ?

- F. 5 a.m.
- G. 5 p.m.
- H. 10 a.m.
- J. 10 p.m.
- K. 12 p.m.

**DO YOUR FIGURING HERE.**

39. Vanessa averaged exactly 12 points per game for 5 basketball games. She scored at least 10 points per game in each of the 5 games. What is the maximum number of points per game she could have scored in any 1 of the 5 games?

- A. 12
- B. 14
- C. 15
- D. 20
- E. 50

40. In the figure below, the circle is centered at  $O$ , the measure of angle  $\angle MON$  ( $m\angle MON$ ) is  $30^\circ$ ,  $m\angle NOP = x^\circ$ , and  $m\angle POR = 80^\circ$ . The length of arc  $\widehat{MR}$  that does NOT contain  $N$  and  $P$  is 4 times the length of minor arc  $\widehat{MN}$ . What is the value of  $x$  ?

(Note: The figure below is NOT drawn to scale.)

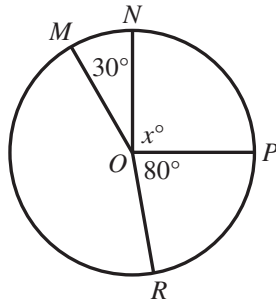

- F. 10
- G. 22
- H. 50
- J. 130
- K. 190

41. Given that  $c^2 + c^9 = 0$ , which of the following is the set of all real values that are possible for  $c$  ?

- A.  $\{-1, 0, 1\}$
- B.  $\{-1, 0\}$
- C.  $\{0, 1\}$
- D.  $\{-1\}$
- E.  $\{0\}$

42. The graph of the function  $y = -2(x - 3)^2 + 1$  in the standard  $(x, y)$  coordinate plane is translated 2 units to the left and 4 units down to create a new function. Which of the following equations defines the new function?

- F.  $y = -2(x - 5)^2 - 3$
- G.  $y = -2(x - 5)^2 + 5$
- H.  $y = -2(x - 3)^2 + 5$
- J.  $y = -2(x - 1)^2 - 3$
- K.  $y = -2(x - 1)^2 + 5$

www.actexam.net



43. For a certain geometric sequence of only positive terms,  $a_3 = \frac{16}{3}$  and  $a_5 = \frac{64}{27}$ . Which of the following numeric expressions gives the value of  $a_8$  ?

- A.  $\frac{2^7}{3^4}$
- B.  $\frac{2^8}{3^5}$
- C.  $\frac{2^9}{3^6}$
- D.  $\frac{2^{10}}{3^4}$
- E.  $\frac{2^{10}}{3^7}$

44. In the standard  $(x,y)$  coordinate plane, what is the  $y$ -coordinate of the intersection point of the 2 lines with equations below?

$$y = -2x + 23$$

$$y = 3x - 7$$

- F. -55
  - G. -16
  - H. 6
  - J. 11
  - K. 55
45. Let  $S$  be the set of all numbers of the form  $b - a$  where  $a$  and  $b$  are real numbers such that  $a > b$ . Which of the following describes  $S$  ?
- A. All negative numbers
  - B. All positive numbers
  - C. All real numbers
  - D. All numbers less than or equal to 0
  - E. All numbers greater than or equal to 0

46. The volume of a solid object is equal to the volume of water it displaces when completely submerged in water. A solid object will be placed in a rectangular tank that has a base of 40 in by 30 in and is filled with water to a uniform depth of 10 in. When the object is completely submerged, the new depth of the water in the tank is  $10\frac{1}{2}$  in. What is the volume, in cubic inches, of the object?

- F. 120
- G. 600
- H. 1,095
- J. 1,260
- K. 2,400

www.crackab.com

**DO YOUR FIGURING HERE.**



47. In the standard  $(x,y)$  coordinate plane below, one of the following absolute value functions is graphed. Which one?

DO YOUR FIGURING HERE.

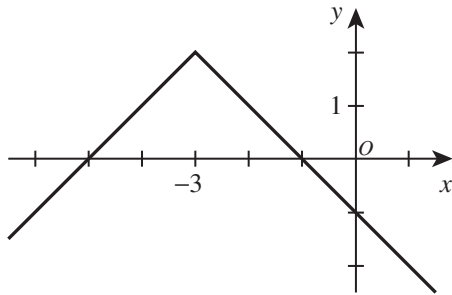

- A.  $f(x) = -|x - 3| + 2$   
 B.  $f(x) = -|x + 3| + 2$   
 C.  $f(x) = -|x - 3| - 2$   
 D.  $f(x) = |x + 3| + 2$   
 E.  $f(x) = |x - 3| + 2$
48. Twenty households in a community were surveyed to determine how many bicycles they owned. The results were recorded and listed below. No household had 6 or more bicycles.

Number of bicycles	Percent of households
0	10%
1	10%
2	25%
3	10%
4	35%
5	10%

Based on the data in the table, what is the expected value of the number of bicycles from a household in this community, rounded to the nearest tenth of a bicycle?

- F. 1.0  
 G. 2.0  
 H. 2.5  
 J. 2.8  
 K. 3.5
49. In  $\triangle ABC$  shown below, the lengths of the sides and an altitude are given in meters. Which of the following expressions gives the area, in square meters, of  $\triangle ABC$ ?

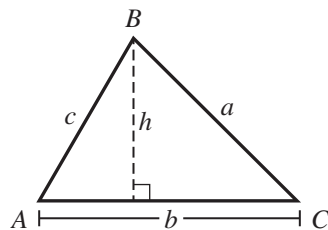

- A.  $hb$   
 B.  $\frac{1}{2}ab$   
 C.  $c \sin A$   
 D.  $abc \sin A$   
 E.  $\frac{1}{2}bc \sin A$



50. Anna will save \$5 in Week 1, \$6 in Week 2, and \$7 in Week 3, saving \$1 more each subsequent week until she saves \$20 in Week 16. She will then start over, saving \$5 in Week 17, then \$6 in Week 18, saving \$1 more each subsequent week, until she saves \$20 in Week 32. This pattern will continue for all 52 weeks of the year. What is the total amount of money Anna will save in 1 full year?

F. \$345  
 G. \$468  
 H. \$510  
 J. \$520  
 K. \$626

51. A student in a chemistry lab had 25 mL of a solution composed of only water and acid. The solution contained 80% water. The student added 50 mL of 100% water to this solution. What is the percent of acid in the new solution?

A.  $6\frac{2}{3}\%$   
 B. 10%  
 C.  $26\frac{2}{3}\%$   
 D.  $33\frac{1}{3}\%$   
 E. 50%

52. A ramp has a horizontal length of 12 feet and a vertical height of 1 foot. Which of the following expressions gives the measure of the acute angle the ramp makes with the horizontal?

F.  $\tan\left(\frac{1}{12}\right)$   
 G.  $\tan(12)$   
 H.  $\tan^{-1}\left(\frac{1}{12}\right)$   
 J.  $\tan^{-1}(12)$   
 K.  $\sqrt{1^2 + 12^2}$

53. For a fund-raising project, your class decided to sell school supplies. They bought the following items to sell: 1,000 pencils at a cost of 5¢ each; 500 pens at 30¢ each; and 500 packages of notebook paper at 50¢ per package. Your class charged these prices: pencils 10¢ each; pens 50¢ each; and notebook paper \$1.00 per package. At the end of the school year, your class had sold 980 pencils, 462 pens, and 459 packages of notebook paper. How much profit did your class make on this project?

(Note: The class donated the unsold items to a youth shelter.)

A. \$450.00  
 B. \$400.00  
 C. \$370.90  
 D. \$367.10  
 E. \$338.00

**DO YOUR FIGURING HERE.**



54. Aimée commutes to work on an interstate highway, and she had been averaging 60 miles per hour over her 1-hour round-trip. Lately, the trip has been taking 15 minutes longer *each way* because of road construction. What is her average speed, in miles per hour, for a round-trip with the construction delays?

F. 30  
G. 35  
H. 40  
J. 45  
K. 50

**DO YOUR FIGURING HERE.**

55. Increasing both the length and width of a rectangle by 20% will increase the area of the rectangle by what percent?

A. 4%  
B. 20%  
C. 40%  
D. 44%  
E. 80%

56. Li is walking from one point on a large model of the standard  $(x,y)$  coordinate plane to another point. She walks only along lines parallel or perpendicular to the  $x$ -axis. The expression  $|6 - 1| + |2 - (-5)|$  gives the minimum distance, in coordinate units, Li walks between which of the following pairs of points?

F.  $(2, 6)$  and  $(-5, 1)$   
G.  $(2, 6)$  and  $(-1, -5)$   
H.  $(6, -5)$  and  $(-1, 2)$   
J.  $(6, -1)$  and  $(2, 5)$   
K.  $(6, 1)$  and  $(2, -5)$

57. Which of the following systems when solved gives values of  $a$  and  $b$  such that  $(3^a)(3^b) = 9$  and  $\frac{2^a}{2^b} = 64$  ?

A.  $a + b = 2$   
 $a - b = 6$   
B.  $a + b = 9$   
 $a - b = 64$   
C.  $ab = 1$   
 $\frac{a}{b} = 6$   
D.  $ab = 2$   
 $\frac{a}{b} = 6$   
E.  $ab = 9$   
 $\frac{a}{b} = 64$

58. For all angle measures  $A^\circ$  greater than  $0^\circ$ , which of the following expressions is equal to  $\cos A^\circ$  ?

F.  $\cos (90 + A)^\circ$   
G.  $\cos (180 - A)^\circ$   
H.  $\cos (180 + A)^\circ$   
J.  $\cos (270 + A)^\circ$   
K.  $\cos (360 - A)^\circ$   
www.actexam.net

**GO ON TO THE NEXT PAGE.**



59. The ellipse  $\frac{x^2}{25} + \frac{y^2}{16} = 1$  is shown in the standard  $(x,y)$  coordinate plane below. The major axis is  $\overline{AD}$ . The minor axis is  $\overline{BF}$ . The foci are  $G$  and  $H$ . Points  $C$  and  $E$  are on the ellipse. Which of the following relationships is true?

DO YOUR FIGURING HERE.

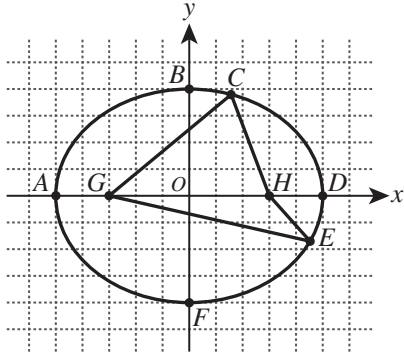

- A.  $AD = BF$   
 B.  $CG + CH = BF$   
 C.  $EG + EH = GH$   
 D.  $CG + CH = 2 \cdot GH$   
 E.  $CG + CH = EG + EH$
60. The rational function graphed in the standard  $(x,y)$  coordinate plane below is undefined for 2 real values of  $x$ .

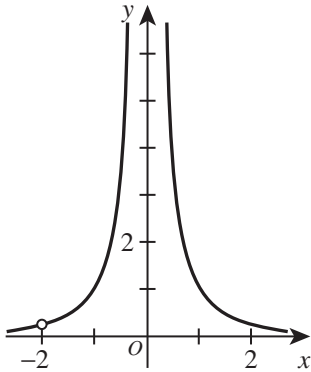

One of the following functions is the graphed function. Which one?

- F.  $y = \frac{x+2}{x(x+2)}$   
 G.  $y = \frac{x-2}{x(x-2)^2}$   
 H.  $y = \frac{(x-2)^2}{x^2(x-2)}$   
 J.  $y = \frac{x+2}{x^2(x+2)}$   
 K.  $y = \frac{x+2}{x^2(x+2)^2}$

END OF TEST 2

STOP! DO NOT TURN THE PAGE UNTIL TOLD TO DO SO.

DO NOT RETURN TO THE PREVIOUS TEST.

## READING TEST

35 Minutes—40 Questions

**DIRECTIONS:** There are several passages in this test. Each passage is accompanied by several questions. After reading a passage, choose the best answer to each question and fill in the corresponding oval on your answer document. You may refer to the passages as often as necessary.

## Passage I

**LITERARY NARRATIVE:** Passage A is from the book *Soundings: The Story of the Remarkable Woman Who Mapped the Ocean Floor* by Hali Felt. Passage B is from the short story “The Open Lot” by Barry Lopez.

## Passage A by Hali Felt

My mother used to draw maps. Not in the cartographic sense—she had no training in that field—but rather in the sense that she rendered them, drew and painted and inked up sheets of paper depicting areas of land that she had studied. She spent hours at the library poring over atlases in the reference section, photocopying in segments the huge pages of the books, then taping them together so she’d have something to work from at home.

10 She liked to complain about all the research she had to do to create even the smallest map. This made sense; as a freelance magazine illustrator, the time she spent on research went largely uncompensated. But she had to do it if her maps were going to meet her editors’  
15 approval, and I think it was actually her favorite part. I remember waking up in the middle of the night when I was little and stumbling in my bare feet to the other side of our apartment. I could hear the soft laugh track of whatever she had on the television to keep her company while she worked, and as I got closer to her studio  
20 I could see the electric light spilling out of it, as if daylight had arrived a few hours early in just this room. And there she’d be, all splayed out on her studio floor, the copied maps spread out like a carpet and a pencil  
25 between her teeth. When I found her on these nights, she’d almost never be looking down at the maps or at the television. Instead, she’d be staring off into what would have been the distance if her futon, her flat files, and her dresser hadn’t been in the way. I thought she  
30 must be thinking about mountains or maybe even plains, and the borders between countries that could shift if she allowed even a tiny tremor in her hand to travel down the wood of her pencil, through the lead, onto the paper. Her illustrations were always meticulous, though; looking at them, I found it obvious that  
35 she reveled in all the necessary detail.

While she also drew other things, I latched onto the maps without any urging. As a kid I sent away for an orienteering manual that taught me how to navigate

40 through the wilderness with only a map and a compass; as a teenager I bought journals and calendars with maps printed on them; and when I moved away from home, I decorated the walls of my bedrooms with maps. I, too, loved how beautiful they were, the grids of the streets,  
45 the curves of rivers, the green amoebas of parks and forests—maps were true, but they were also art, a starting point for me to imagine what they represented, what they meant, what was actually on the ground.

## Passage B by Barry Lopez

Jane Weddell took any of several routes from her  
50 apartment on West Sixty-fourth Street to the museum on West Seventy-seventh, depending. Her path was determined by a pattern of complexity outside her thought, the result not solely of her emotional state but also of her unconscious desire, say, to avoid a wind  
55 blowing black grit down Columbus Avenue on the morning when she was wearing a new blouse for the first time. Or she gave in to whim, following a path defined by successive flights of pigeons, a path that might lead her east down Seventy-third Street to the  
60 park instead of across on Seventy-fifth or Sixty-eighth.

The pattern of her traverses from one day to the next gave her a sense of the vastness in which she lived; she was aware not only of the surface of each street but, simultaneously, of the tunneling below, which carried  
65 water mains and tree roots, like the meandering chambers of gophers. And ranging above, she knew without having to look, were tiers upon tiers of human life, the joy and anger and curiosity of creatures like herself.

She arrived by one or another of her footpaths—  
70 she imagined them, lying awake at night, like a *rete mirabile*, a tracery over the concrete, the tar, and the stone—at a room on the second floor of the Museum of Natural History, a vaulted, well-lit space in which she worked six or seven hours a day, preparing fossils of  
75 marine organisms from the Cambrian period and the Precambrian era. It was her gift to discern in the bits of rock placed before her lines of such subtlety that no one who beheld her excisions could quite believe what she had done. Under the bold, piercing glass of a microscope, working first with the right hand and then, when the muscles in that hand lost their strength, the left, she removed clay and sand and silt, grain by grain, her eyes focused on suggestions indescribably ambivalent. When she finished and set the pieces apart, one saw in stone a



85 creature so complete, even to the airiness of its antennae, that it rivaled something living.

Passage A: Excerpt from “Introduction” from the book *SOUNDINGS: The Story of the Remarkable Woman Who Mapped the Ocean Floor* by Hali Felt. Copyright © 2012 by Hali Felt. Used by permission of Henry Holt and Company, LLC. All rights reserved.

Passage B: From the short story “The Open Lot” by Barry Lopez (©1994 by Barry Holstun Lopez). Used with permission.

Questions 1 and 2 ask about Passage A.

- According to the narrator of Passage A, the mother’s favorite part of illustrating maps was most likely:
  - being able to concentrate on completing one project at a time.
  - having the creative freedom to improvise aspects of her renderings.
  - researching the land she had to depict.
  - working closely with magazine editors.
- It can reasonably be inferred from Passage A that both the narrator and her mother appreciate maps for their:
  - triviality.
  - beauty.
  - variability.
  - obscurity.

Questions 3–6 ask about Passage B.

- In Passage B, details about how Weddell chooses the path she takes to work help characterize Weddell as someone who is:
  - overly analytical.
  - frequently careless.
  - easily distracted.
  - somewhat impulsive.
- In the context of Passage B, which of the following details most directly illustrates the “vastness” (line 62) in which Weddell lives?
  - “A wind blowing black grit” (lines 54–55)
  - “Successive flights of pigeons” (line 58)
  - “Tiers upon tiers of human life” (line 67)
  - “One or another of her footpaths” (line 69)
- The main point of the last paragraph of Passage B is that Weddell:
  - studies fossils from the Cambrian period and the Precambrian era.
  - works with living marine organisms as well as fossils.
  - has a unique talent for excising fossils.
  - can excise fossils particularly quickly.

www.crackab.com

- Based on Passage B, the reaction that people have to Weddell’s work can best be described as one of:
  - amusement.
  - apathy.
  - disdain.
  - awe.

Questions 7–10 ask about both passages.

- The narrative approach of Passage A and Passage B is similar in that both passages:
  - use a first person narrator to relate events from the past.
  - focus on an isolated event and its effect on the lives of the main characters.
  - present a detailed description of routine events in the lives of the main characters.
  - blend figurative language with highly technical scientific language.
- Based on the passages, in terms of their work, the mother in Passage A and Weddell in Passage B both can be described as:
  - meticulous.
  - egotistical.
  - untrained.
  - pioneering.
- In the passages, the details “the grids of the streets, the curves of rivers, the green amoebas of parks and forests” (lines 44–46) and “the tunneling below, which carried water mains and tree roots, like the meandering chambers of gophers” (lines 64–66) both function to:
  - describe the cities in which the narrator of Passage A and Weddell from Passage B live.
  - highlight the fascination that the narrator of Passage A and Weddell from Passage B have with the world in which they live.
  - describe in figurative terms the elements typically included on maps of New York City.
  - illustrate the interest that the narrator of Passage A and Weddell from Passage B have in maps.
- The narrator of Passage A states that “maps were true, but they were also art” (line 46). Which of the following quotations from Passage B makes a similar point about Weddell’s completed fossil excisions?
  - “She imagined them, lying awake at night, like a *rete mirabile*, a tracery over the concrete, the tar, and the stone” (lines 70–72).
  - “She worked six or seven hours a day, preparing fossils of marine organisms” (lines 73–75).
  - “Working first with the right hand and then, when the muscles in that hand lost their strength, the left” (lines 80–81).
  - “One saw in stone a creature so complete, even to the airiness of its antennae, that it rivaled something living” (lines 84–86).

## Passage II

**SOCIAL SCIENCE:** This passage is from the article “Mad About Shells” by Richard Conniff.

Anthropologists have identified beads made from shells in North Africa and Israel at least 100,000 years ago as among the earliest known evidence of modern human culture.

5 Since then various societies have used shells not just as ornaments, but also as blades and scrapers, oil lamps, currency, cooking utensils, boat bailers, musical instruments and buttons, among other things. Marine snails were the source of the precious purple dye, 10 painstakingly collected one drop at a time, that became the symbolic color of royalty. Shells may also have served as models for the volute on the capital of the Ionic column in classical Greece and for Leonardo da Vinci’s design for a spiral staircase in a French chateau. 15 In fact, shells inspired an entire French art movement: Rococo, a word blending the French *rocaille*, referring to the practice of covering walls with shells and rocks, and the Italian *barocco*, or Baroque. Its architects and designers favored shell-like curves and other intricate 20 motifs.

The craving for shells was even powerful enough to change the fate of a continent: at the start of the 19th century, when rival French and British expeditions set out for the unknown coasts of Australia, the British 25 moved faster. The French were delayed, one of those on board complained, because their captain was more eager “to discover a new mollusk than a new landmass.” And when the two expeditions met up in 1802 at what is now Encounter Bay, on the south coast of Australia, 30 a French officer complained to the British captain that “if we had not been kept so long picking up shells and catching butterflies . . . you would not have discovered the south coast before us.” The French went home with their specimens, while the British quickly moved to 35 expand their colony on the island continent.

The madness for shells that took hold of European collectors from the 17th century onward was largely a byproduct of colonial trade and exploration. Along with 40 spices and other merchandise, ships of the Dutch East India Company brought back spectacularly beautiful shells from what is now Indonesia, and they became prized items in the private museums of the rich and royal. “Conchylomania,” from the Latin *concha*, for cockle or mussel, soon rivaled the Dutch madness for 45 collecting tulip bulbs, and often afflicted the same people. One Amsterdam collector, who died in 1644, had enough tulips to fill a 38-page inventory, according to *Tulipmania*, a recent history by Anne Goldgar. But he also had 2,389 shells, and considered them so precious that, a few days before his death, he had them put 50 away in a chest with three separate locks. The three executors of his estate each got a single key, so they could show the collection to potential buyers only when all three of them were present. Dutch writer Roemer 55 Visscher mocked both tulip maniacs and “shell-

lunatics.” Shells on the beach that used to be playthings for children now had the price of jewels, he said. “It is bizarre what a madman spends his money on.”

And he was right: at one 18th-century auction in 60 Amsterdam, some shells sold for more than paintings by Jan Steen and Frans Hals, and only slightly less than Vermeer’s now-priceless *Woman in Blue Reading a Letter*. The collection also included a *Conus gloriamaris* shell, for which the owner had paid about three 65 times what his estate was getting for the Vermeer.

From a financial perspective, valuing shells over Dutch masters may rank among the dumbest purchases ever. There are only 30-some known Vermeer paintings on earth. But the scarcity that could make a shell seem 70 so precious was almost always illusory. For instance, *C. gloriamaris*, a four-inch-long cone covered in a delicate fretwork of gold and black lines, was for centuries among the most coveted species in the world, known from only a few dozen specimens. One shell-trade story 75 held that a wealthy collector who already owned a specimen managed to buy another at auction and, in the interest of scarcity, promptly crushed it underfoot. To maintain prices, collectors also spread the rumor that an earthquake had destroyed the species’ habitat in the 80 Philippines and rendered it extinct. Then in 1970, divers discovered the mother lode in the Pacific, north of Guadalcanal Island, and the value of *C. gloriamaris* plummeted. Today you can buy one for roughly the price of dinner for two at a nice restaurant. And paintings 85 by Vermeer? The last time one came on the market, in 2004, it went for \$30 million. (And it was a minor and slightly questionable one at that.)

From the article “Mad About Shells” by Richard Conniff (©2009 by Smithsonian Institution). Used with permission.

11. The main purpose of the passage is to:
- A. consider the attachments people have had to shells, from ancient times to the height of shell collecting and beyond.
  - B. show how shells have proven to be a less stable investment than Dutch paintings.
  - C. document the various influences that shells and shell collecting have had on international trade.
  - D. describe how the Dutch people acquired an interest in shell collecting from French and British shell collectors.
12. The language used to describe the shell collectors in the fourth paragraph (lines 36–58) most nearly characterizes them as:
- F. irrational.
  - G. fearless.
  - H. positive.
  - J. unreliable.

13. It can most reasonably be inferred that the beads mentioned in the first paragraph were most likely used as:
- A. currency.
  - B. trade goods.
  - C. weights for measuring.
  - D. ornamentation.
14. In the context of the passage, the primary purpose of the second paragraph (lines 5–20) is to:
- F. specify some of the roles shells have played in human culture.
  - G. summarize why shells stopped being used as practical objects.
  - H. illustrate how shells became more celebrated as their monetary value increased.
  - J. explain that shells inspired competing art movements.
15. As portrayed in the fourth paragraph (lines 36–58), compared to Dutch tulip bulb collectors, Dutch shell collectors were:
- A. less obsessed with the security of their collections.
  - B. similarly enthusiastic in the pursuit of their collections.
  - C. more willing to make risky investments with their collections.
  - D. more meticulous in keeping track of their collections.
16. The author’s portrayal of the eighteenth-century Amsterdam auction in the fifth paragraph (lines 59–65) primarily serves to:
- F. emphasize how quickly the prices for shells had risen in the eighteenth century.
  - G. indicate that shell collecting had become as widespread as art collecting.
  - H. pinpoint the moment when collectable shells started to command higher prices than paintings.
  - J. demonstrate that shell collectors were willing to buy shells at prices that rivaled those of paintings.
17. According to a source cited in the passage, one reason a British expedition reached Australia before a French expedition did was because the French expedition:
- A. didn’t have accurate maps.
  - B. had less experience with long voyages.
  - C. spent time along the way collecting shells.
  - D. spent time along the way trading butterflies for shells.
18. Based on the passage, which of the following provides the best paraphrase of the statement in lines 69–70?
- F. Shell collectors often just guessed what the value of a shell was.
  - G. The rarity that caused some shells to be so valuable was a perceived rarity, not an actual one.
  - H. The scarcer a particular shell was, the more inflated its value could become.
  - J. Shell collectors destroyed certain shells to increase their rarity.
19. According to the passage, what caused the value of *C. gloriamaris* shells to plummet?
- A. Divers discovered an area where the shells were common.
  - B. One collector sold 2,389 shells.
  - C. An earthquake destroyed the species’ habitat.
  - D. Demand for other kinds of shells rose steeply.
20. In the passage, what is one piece of evidence used by the author to emphasize the modern-day difference between the value of *C. gloriamaris* shells and the value of Vermeer paintings?
- F. He points out there are currently about three dozen specimens of *C. gloriamaris*.
  - G. He tells the story about one early shell collector crushing a *C. gloriamaris* shell.
  - H. He quotes Visscher’s statement that shells are playthings for children.
  - J. He cites the price of the most recently sold Vermeer painting.

### Passage III

**HUMANITIES:** This passage is from the article “Culture Shock Camp: Sending a Message” by Tara Gatewood.

When the hip-hop phenomenon really began to take hold in the 1980s, a seed of inspiration was planted in Native Oklahoma. Several decades later, it’s grown into a youth-empowerment movement called Culture Shock Camp.

One person who’s been part of the evolution since the beginning says he counts himself lucky to have inserted himself onto the scene and watched it unfold over the years. What he didn’t know then was that stepping to the ones and twos or the DJ table would someday be the reason many Native youth would find their inner strength and connect with Native culture.

“For some people, all they need is that one time or that one person to share those few words of encouragement or just listen,” says Brian Frejo (Pawnee/Seminole), an actor, music producer and promoter, rapper and motivational speaker. “Just that can change their life.”

This is the story of IndiGenius Shock B (aka Brian Frejo) and Culture Shock Camp, and what’s been seen as a viral motivational movement.

As a young boy, Frejo learned how music could move people. At first, it was the irresistible allure of the world of music and its ability to open up a space that had him transferring songs from vinyl to cassette tape for his own enjoyment. Some of the early tracks at his mix command were by James Brown, Elvis, the Temptations and other artists. The work of a DJ—arranging and rearranging songs—felt freeing, he says.

“That energy that comes out of music puts vibrations out in the air and hits people’s bodies. It connects to their spirit, and that’s what makes them move. Whether they are moving physically, mentally or emotionally, it is a serious lesson of music,” he says.

As a Native tied to his traditional roots and the powwow world, Frejo found that his spinning and hip-hop didn’t come without criticism from within his own tribe. “At first I was told, ‘That’s not Native, that’s not Indian. Why [are you] doing that?’” he says. “I was also asked why I was dressed like that.” But he didn’t care, because he loved the music and the culture.

Being in the spotlight as a DJ on the mainstream Oklahoma scene, Frejo says he was constantly being asked his ethnicity. It would “blow people away” to learn he was Native, he says, leading people to take notice. “I was proud to be known as a Native DJ. I wanted to represent our people,” he says. “It started something.”

There was also a bigger message to communicate through this cultural intersection. “I wanted people to

know Natives had talent and could go out there and be successful,” Frejo says. And he wanted to send the message to Native people that success could be theirs, too. “I was seeing different races get exposure. I figured we needed to do this,” Frejo says.

In 1997, his idea to show off Native rappers and DJs jumping into the hip-hop mix turned into a huge event: the first annual Tribal Hip-Hop Summit, which brought together youth and artists from different tribes to the historic Will Rogers Theatre in Oklahoma City.

“We wanted a name for the summit that connected to culture,” Frejo says. When he heard that term, he thought, “Yes ‘culture shock’! It’s kind of like a catchphrase when someone is somewhere and they are like, ‘Whoa,’ because of the culture.” A year later, he and his crew picked up the name Culture Shock Camp and Frejo’s DJ name came to be Shock B. Years later, it would evolve to IndiGenius Shock B. “It wasn’t planned out with a mission statement or a big goal; it was more organic as it was growing and progressing,” he says.

The need for Native youth to connect with a healthy, positive cultural message led Culture Shock Camp to hit the road. Frejo, along with his recording-artist brother Marcus “Queese IMC” Frejo (Pawnee/Seminole), dancer and vocalist sister Happy Frejo (Pawnee/Seminole), and Marcus Anthony Guinn (Osage/Potawatomi/Delaware; aka Emcee One) connected with different communities as the core group. As time went on, others joined the presentations, including b-boy crews from Arizona and Oklahoma.

The biggest message Frejo says they relayed to youth was to be proud of their identity. “I was once told, ‘You are going to be the leaders to bring the culture back. You have to make a choice to know your identity, our language, our culture, our songs.’” Since its inception, Culture Shock Camp has shared its words, music and energy with youth from different tribal nations, some of which include the Pawnee, Meskwaki, Suquamish, Blackfeet and Menominee nations.

From the article “Culture Shock Camp: Sending a Message” by Tara Gatewood. Copyright ©2014 Media Concepts Group, Inc. nativepeoples.com.

21. Which of the following events mentioned in the passage occurred before the first annual Tribal Hip-Hop Summit?
- A. Frejo adopted the DJ name IndiGenius Shock B.
  - B. Frejo recruited b-boy crews from Arizona to join Culture Shock Camp.
  - C. Frejo wrote the mission statement for Culture Shock Camp.
  - D. Frejo transferred songs from vinyl to cassette tape for his own enjoyment.

22. The passage most strongly suggests that one reason Frejo finds the work of a DJ freeing is that:
- F. it allows him to encourage physical movement.
  - G. it allows him to focus solely on music vibrations.
  - H. his arrangements surprise crowds with unorthodox inclusions from artists like Elvis.
  - J. his arrangements connect with people and energize them on multiple levels.
23. Which of the following statements best summarizes the seventh paragraph (lines 35–41)?
- A. Frejo often encouraged tribe members to listen to hip-hop music, despite their reluctance.
  - B. Frejo had to answer questions about hip-hop music before some tribe members would approve of his participation.
  - C. Frejo remained devoted to hip-hop, even though some tribe members failed to see its connection to Native culture.
  - D. Frejo felt more of a connection to hip-hop culture than to Native culture, to the disappointment of some tribe members.
24. In the passage, Frejo describes the growth of Culture Shock Camp as:
- F. slowgoing.
  - G. unorganized.
  - H. organic.
  - J. predictable.
25. The main point of the eighth and ninth paragraphs (lines 42–55) is that, as a Native DJ, Frejo has been able to:
- A. teach his DJ skills to audiences of Natives and non-Natives alike.
  - B. witness people from all races gain exposure through hip-hop culture.
  - C. use his own talent to draw attention to Native talent in general and to encourage other Natives to pursue their own talents.
  - D. reject the mainstream Oklahoma music scene and endorse innovation within the music industry in general.
26. One main purpose of the twelfth paragraph (lines 72–81) is to:
- F. characterize the relationship between Frejo and his siblings.
  - G. list the places Culture Shock Camp has traveled.
  - H. describe a typical Culture Shock Camp presentation.
  - J. demonstrate how Culture Shock Camp’s presentations have grown.
27. According to the passage, regarding change in certain people’s lives, Frejo believes change can happen:
- A. in a moment; the first attempt at writing music can be an eye-opening experience.
  - B. in a moment; one sincere and meaningful interaction can have lifelong effects.
  - C. over time; individuals need repeated exposure to positive messages in order to internalize them.
  - D. over time; only through a series of positive choices can an individual start to see change.
28. In the passage, the author uses the phrase “open up a space” (line 24) to help highlight that Frejo valued music’s ability to let him:
- F. express creativity and originality.
  - G. entertain crowds in various venues.
  - H. persuade others to enjoy his music.
  - J. impress his family members with his talents.
29. Based on the passage, the main reason Culture Shock Camp began traveling to perform was that Frejo:
- A. sensed that the summit’s popularity was drastically increasing.
  - B. felt compelled to bring his message to Native youth across the country.
  - C. no longer had obligations in Oklahoma as a music producer.
  - D. wanted to add b-boy crews to the summit’s presentations but could not locate any in Oklahoma.
30. The passage most strongly suggests that, in terms of reviving and maintaining Native culture, Frejo feels:
- F. a nagging restlessness to bring Native culture to all genres of music.
  - G. slightly overwhelmed by the number of people who still need to hear his message.
  - H. a great deal of responsibility to pass the culture down to younger generations.
  - J. immensely guilty about not starting his mission earlier in life.

## Passage IV

**NATURAL SCIENCE:** This passage is from the book *Feathers: The Evolution of a Natural Miracle* by Thor Hanson.

In the passage, *airfoil* refers to the shape of a wing. Covert feathers serve as covers for other feathers.

Textbook diagrams of airfoils regularly leave out a critical detail: turbulence. Air passing around a wing never actually moves in the smooth lines of illustration—it swirls and eddies in complex patterns that change constantly with every subtlety of temperature, air pressure, wind speed, wing shape, and angle. There are layers of air dragged along with the wing, vortices tumbling above its surfaces, and spirals jetting off the tips. The process is far too complex for any drawing, but understanding it is critical to understanding drag, the natural resistance to a wing’s forward motion. Any reduction in drag increases flight efficiency, offering immediate fuel savings to airlines. And no one reduces drag better than birds.

If you’ve ever flown in a window seat, you may have admired the silvery shine of an airplane wing and watched its several flaps raise and lower at various times during the flight. It’s a precise and beautifully designed instrument, but must look terribly crude to a bird, whose own wings can flap and flex, extend and contract, spread, narrow, tuck, and twist, responding instantly to ever-changing conditions. Taken together, the overlapping flight feathers create a single dynamic airfoil. But they can also move independently and are themselves shaped like airfoils, acting as individual winglets within the greater whole. Vultures, eagles, and other soaring birds use small adjustments of their spread wing-tip “fingers” to manipulate air currents or change speed and orientation, and all birds utilize feather movements to instinctively alter the turbulence patterns around their wings. Slots can be opened or closed to direct air between primaries; covert feathers can be raised or lowered like tiny flags—the possibilities are endless.

Teasing apart these intricacies challenges even the most advanced computer models, but engineers have already learned that adding artificial “winglets” to the tips of airplane wings can mimic the efficiency of a soaring raptor. Passenger jets retrofitted with winglets have seen their fuel use drop by as much as 6 percent, a substantial savings considering that a fully loaded 747 can burn through a gallon or more every second. Now in common use, these small vertical fins have saved the airline industry billions of dollars in fuel costs. A potentially more lucrative lesson can be summarized in one unexpected word: *fuzziness*.

Photographs of birds in flight often show splayed and uneven flight feathers, or coverts lifted at sharp angles above the wing—like Ken Franklin’s amazing pictures of a falcon catching shorebirds. Engineers now believe this intentional “roughening” of the wing surface may substantially reduce turbulence and drag. A fully feathered jetliner is probably out of the question,

but simulations suggest that just covering the wings with simple bristles could improve flight efficiency by as much as 15 percent. Typically, air passing over the surface of a wing (or any airfoil) breaks apart into tiny eddies that pull away from the surface, a form of turbulence that results in additional drag and pockets of dead air directly behind the wing. When bicyclists tuck into the slipstream behind a lead rider, they’re taking advantage of this principle—saving energy by riding in a low-pressure, low-turbulence position. It’s counterintuitive, but rough surfaces can help reduce drag by manipulating the formation of eddies and keeping them close to the airfoil surface. Years from now, you may peer out an airplane window and see a fuzzy wing, each bristle the manufacturer’s best approximation of a feather.

Managing the airflow around wings can have the added benefit of substantially reducing aircraft noise, an important consideration for anyone living on a busy flight path. When owls pass overhead, their eerily silent wing strokes seem otherworldly, and they’ve long been linked to mythologies of the spirit realm. But there is nothing supernatural about an owl’s flight—their wings simply part the air in a different way. Owl feathers feature barb extensions on the leading and trailing edges that reduce turbulence over *individual feathers* as well as the entire wing, increasing efficiency but, most important, muffling the sound of their approach. This stealth gives them a key advantage over the wary and sharp-eared mammals and birds they prey upon. The promise of quieter airplanes makes owl feathers an intriguing model for commercial carriers, whose take-offs and landings at urban airports are dictated in part by sound levels.

Copyright © 20110101 Hanson, Thor. Reprinted by permission of Basic Books, a member of the Perseus Books Group.

31. The main idea of the passage is that:
- A. bird wings and feathers are more specialized than airplane wings are.
  - B. airplane wings have less drag than bird wings, but bird wings are more efficient than airplane wings.
  - C. features inspired by bird wings and feathers can improve the performance of airplane wings.
  - D. features of airplane wings that were once thought to be innovative have long been used by birds.
32. The author’s use of the word “fuzziness” in line 46 most nearly serves to:
- F. introduce an idea that is developed in the next paragraph.
  - G. summarize the ideas presented earlier in the paragraph.
  - H. define the word as it relates to winglets.
  - J. dismiss the benefits of winglets on passenger jets as trivial.

33. According to the passage, textbook diagrams of airfoils can't effectively portray turbulence because:
- A. turbulence moves in such smooth lines that it's too subtle to draw.
  - B. turbulence is too multidimensional and variable to be captured in a drawing.
  - C. the movement of air is invisible, making the portrayal of turbulence a speculative undertaking.
  - D. scientists don't understand all the factors that create and affect turbulence.
34. When the author states "the possibilities are endless" (lines 33–34), he is most nearly referring to the idea that:
- F. each bird species uses its wings differently than other bird species.
  - G. feathers resemble flags because they can be raised or lowered.
  - H. only computer models can quantify all the differences between airplane wings and bird wings.
  - J. birds can move their feathers in innumerable ways.
35. In the passage, the author demonstrates the pockets of dead air that can form behind a wing by mentioning:
- A. bicyclists closely following a lead rider.
  - B. artificial winglets retrofitted to passenger jets.
  - C. the flaps that raise and lower on an airplane wing.
  - D. textbook diagrams of airfoils.
36. According to the passage, the airline industry has an interest in reducing the drag of airplane wings because lower drag results in:
- F. smoother takeoffs and landings.
  - G. less turbulence behind wings.
  - H. higher cruising speeds.
  - J. lower fuel consumption.
37. As it is used in line 43, the word *common* most nearly means:
- A. shared.
  - B. widespread.
  - C. average.
  - D. public.
38. Which of the following statements best represents the passage's characterization of the prospect of building jetliners covered with feathers?
- F. Work on such jetliners is underway.
  - G. Scientists think that such jetliners are a worthwhile goal.
  - H. It's unlikely that such jetliners will be built.
  - J. Building such jetliners has already been shown to be impossible.
39. According to the passage, owls' wing strokes are silent because owl wings feature:
- A. overlapping flight feathers.
  - B. covert feathers that can be raised or lowered.
  - C. bristles on the tail feathers.
  - D. feathers with barb extensions.
40. As it is used in line 86, the word *dictated* most nearly means:
- F. uttered.
  - G. commanded.
  - H. determined.
  - J. required.

**END OF TEST 3**

**STOP! DO NOT TURN THE PAGE UNTIL TOLD TO DO SO.**

**DO NOT RETURN TO A PREVIOUS TEST.**



## SCIENCE TEST

35 Minutes—40 Questions

**DIRECTIONS:** There are several passages in this test. Each passage is followed by several questions. After reading a passage, choose the best answer to each question and fill in the corresponding oval on your answer document. You may refer to the passages as often as necessary.

You are NOT permitted to use a calculator on this test.

## Passage I

Enzymes *catalyze* (speed up) chemical reactions. The *pancreas* (a digestive organ) secretes 4 types of digestive enzymes—amylase, nuclease, lipase, and protease. Each type of enzyme catalyzes the breakdown of a different type of molecule in the digestive tract (see Table 1).

Table 1	
Type of enzyme	Catalyzes the breakdown of:
Amylase	<i>starch</i> (a complex sugar)
Nuclease	nucleic acid
Lipase	<i>triglyceride</i> (a fat)
Protease	protein

An enzyme's activity can be affected by pH. Figure 1 shows, for each type of enzyme listed in Table 1, how *relative activity* (percent of the greatest measured activity) varies with pH.

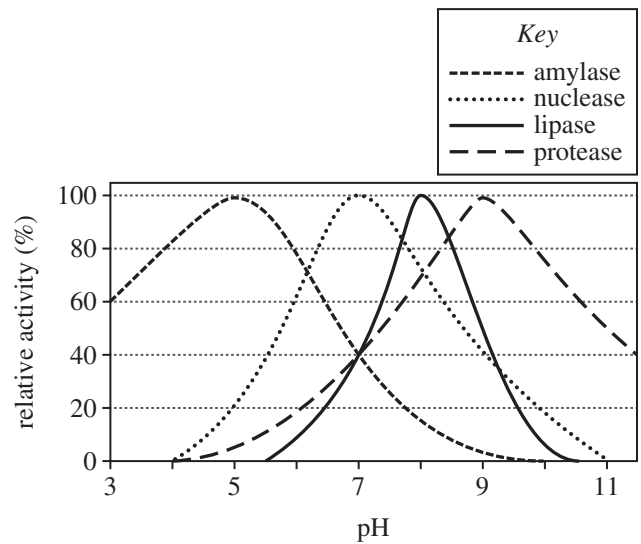

Note: Assume that, for this range of pH values, if no data is shown for a type of enzyme, its relative activity is 0%.

Figure 1





- According to Figure 1, at a pH of 6, which types of enzymes have a relative activity of less than 40%?
  - Amylase and nuclease only
  - Amylase and protease only
  - Lipase and nuclease only
  - Lipase and protease only
- According to Figure 1, as the pH increases from 7 to 9, the relative activity for amylase:
  - decreases only.
  - increases only.
  - decreases and then increases.
  - increases and then decreases.
- Based on Table 1 and Figure 1, the type of enzyme that catalyzes the breakdown of triglyceride has a relative activity of approximately 50% at which of the following pH values?
  - 4
  - 6
  - 9
  - 11
- Suppose that after a certain enzyme is added to a mixture of starch, nucleic acid, triglyceride, and protein, only the concentration of protein decreases. Based on Table 1, the enzyme would most likely be classified as:
  - amylase.
  - nuclease.
  - lipase.
  - protease.
- Based on Figure 1, which type of enzyme is active over the smallest range of pH values?
  - Amylase
  - Nuclease
  - Lipase
  - Protease
- Based on Table 1 and Figure 1, at a pH of 7, the relative activity for the type of enzyme that catalyzes the breakdown of starch is approximately the same as the relative activity for the types of enzymes that catalyze the breakdown of which of the types of molecules listed below?
  - Nucleic acid
  - Triglyceride
  - Protein
  - I and II only
  - I and III only
  - II and III only
  - I, II, and III



## Passage II

In an atom, an electron exists in one of several *quantum states* (configurations). Each quantum state can be specified by a set of numbers. Two of these numbers are called  $n$  and  $j$ . In addition, each quantum state is associated with a type of *orbital* (a region surrounding the nucleus).

The figure shows, for  $n \leq 4$  in a hydrogen atom, every possible combination of  $n$  and  $j$  for which a quantum state exists. The figure also shows, for each state, the energy—which is determined by the values of  $n$  and  $j$ —and the orbital type:  $s$ ,  $p$ ,  $d$ , or  $f$ .

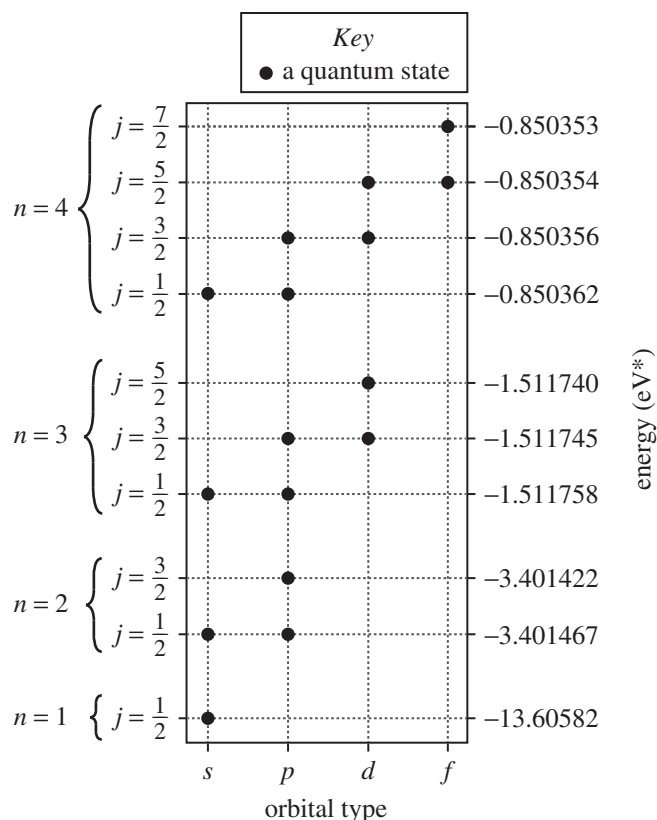

\*electron volts

Note: Quantum states within an atom have negative energies. In this figure, energy increases from bottom to top.

7. Based on the figure, which of the following combinations of  $n$ ,  $j$ , and orbital type does NOT correspond to a quantum state?

	$n$	$j$	orbital type
A.	1	$\frac{1}{2}$	$s$
B.	2	$\frac{3}{2}$	$p$
C.	3	$\frac{1}{2}$	$s$
D.	4	$\frac{5}{2}$	$p$

8. Based on the figure, as the value of  $n$  increases, the number of possible values for  $j$ :

- F. increases only.  
G. decreases only.  
H. increases and then decreases.  
J. decreases and then increases.

9. According to the figure, for  $n = 3$ , how many quantum states are possible?

- A. 1  
B. 3  
C. 5  
D. 7

10. The first 5 orbital types are  $s$ ,  $p$ ,  $d$ ,  $f$ , and  $g$ , in order of increasing complexity. Based on the figure, the quantum states associated with  $g$ -type orbitals would most likely have energies that are:

- F. less than  $-1.51$  eV.  
G. between  $-1.51$  eV and  $-0.85$  eV.  
H. between  $-0.85$  eV and  $0$  eV.  
J. greater than  $0$  eV.

**4****4**

11. Based on the figure, compared with the energy of any of the  $n = 2$  states, the energy of the  $n = 1$  state is approximately:

- A. 1 eV greater.
- B. 1 eV less.
- C. 10 eV greater.
- D. 10 eV less.

12. Based on the figure, does a combination of  $n$  and  $j$  provide enough information to distinguish between any two quantum states?

- F. No; each combination of  $n$  and  $j$  shown in the figure is associated with a single quantum state.
- G. No; several combinations of  $n$  and  $j$  shown in the figure are each associated with more than one quantum state.
- H. Yes; each combination of  $n$  and  $j$  shown in the figure is associated with a single quantum state.
- J. Yes; several combinations of  $n$  and  $j$  shown in the figure are each associated with more than one quantum state.

**Passage III**

*Paramacrobiotus richtersi* (a species of microscopic invertebrate) are often found living on moist leaf litter and mosses. When their surrounding environment dries out, active *P. richtersi* become *desiccated* (dried out) and may go dormant. Compared to active *P. richtersi*, dormant *P. richtersi* have a greatly reduced metabolic rate and can survive for years without food or water. Dormant *P. richtersi* can become active again once they are rehydrated.

An experiment was conducted to determine whether exposure to the high levels of ionizing radiation experienced in Earth orbit affects the survival of dormant *P. richtersi*.

*Experiment*

Four groups (Groups 1–4) were prepared with 8 sterilized petri dishes each. Then, a substrate—either 5.5 g of dry leaf litter or sterilized filter paper—was placed in dishes in a group. Next, 100 dormant *P. richtersi* were added to each dish. Groups 1 and 3 were transported into Earth orbit for 12 days, while Groups 2 and 4 remained on Earth (see Table 1). All four groups were kept at the same temperature and humidity throughout the experiment.

Group	Type of substrate added	Transported into Earth orbit?
1	leaf litter	yes
2	leaf litter	no
3	filter paper	yes
4	filter paper	no

Once Groups 1 and 3 were returned to Earth, the *P. richtersi* in all four groups were rehydrated and the average percent survival (percent of the *P. richtersi* that were alive) was determined for each group (see Figure 1).

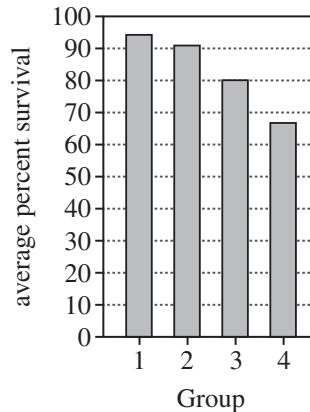

Figure 1

Figure 1 adapted from L. Rebecchi et al., "Resistance of the Anhydrobiotic Eutardigrade *Paramacrobiotus richtersi* to Space Flight (LIFE-TARSE mission on FOTON-M3)." ©2011 by Blackwell Verlag GmbH.

13. Based on the description of the experiment, in what order were the following 3 steps performed?
1. *P. richtersi* were rehydrated.
  2. *P. richtersi* were added to each petri dish.
  3. A substrate was added to each petri dish.
- A. 1, 2, 3  
 B. 1, 3, 2  
 C. 3, 2, 1  
 D. 3, 1, 2
14. Were the *P. richtersi* with the smallest average percent survival transported into Earth orbit or did they remain on Earth, and were they kept in leaf litter or on filter paper?
- F. Transported into Earth orbit; leaf litter  
 G. Transported into Earth orbit; filter paper  
 H. Remained on Earth; leaf litter  
 J. Remained on Earth; filter paper



15. In which state would an individual *P. richtersi* more likely require a greater number of calories per minute, dormant or active?
- A. Dormant; the metabolic rate of a dormant *P. richtersi* is lower than that of an active *P. richtersi*.
  - B. Dormant; the metabolic rate of a dormant *P. richtersi* is higher than that of an active *P. richtersi*.
  - C. Active; the metabolic rate of an active *P. richtersi* is lower than that of a dormant *P. richtersi*.
  - D. Active; the metabolic rate of an active *P. richtersi* is higher than that of a dormant *P. richtersi*.
16. A scientist predicted that the average percent survival of *P. richtersi* kept in leaf litter would be lower in dishes transported into space than in dishes remaining on Earth. Are the results of the experiment consistent with the scientist's prediction?
- F. No; the average percent survival was lower in Group 1 than in Group 2.
  - G. No; the average percent survival was lower in Group 2 than in Group 1.
  - H. Yes; the average percent survival was lower in Group 1 than in Group 2.
  - J. Yes; the average percent survival was lower in Group 2 than in Group 1.
17. Consider the question "Do dormant *P. richtersi* kept in a substrate that resembles their natural environment or those kept on filter paper have a greater chance of surviving exposure to the high levels of ionizing radiation experienced in Earth orbit?" The results of which 2 groups should be compared to best answer this question?
- A. Groups 1 and 2
  - B. Groups 1 and 3
  - C. Groups 2 and 4
  - D. Groups 3 and 4
18. The percent survival of *P. richtersi* in a single petri dish in the experiment is given by which of the following expressions?
- F.  $\left( \frac{\text{number of } P. richtersi \text{ surviving}}{100} \right) \times 100\%$
  - G.  $\left( \frac{\text{number of } P. richtersi \text{ surviving}}{800} \right) \times 100\%$
  - H.  $\left( \frac{100}{\text{number of } P. richtersi \text{ surviving}} \right) \times 100\%$
  - J.  $\left( \frac{800}{\text{number of } P. richtersi \text{ surviving}} \right) \times 100\%$
19. What was the dependent variable in the experiment?
- A. Type of substrate added to the petri dishes
  - B. Average percent survival
  - C. Temperature
  - D. Level of ionizing radiation

**Passage IV***Introduction*

*Nitrobenzene* ( $C_6H_5NO_2$ ) is a molecule consisting of a *nitro group* ( $-NO_2$ ) attached to a *benzene ring* (a ring of 6 carbon atoms connected by alternating single and double covalent bonds). A teacher asked 4 students to predict what carbon-containing products are formed when nitrobenzene and bromine ( $Br_2$ ) react in the presence of solid ferric bromide ( $FeBr_3$ ), and also how fast those products are formed. Figure 1 shows a representation of this reaction; each C atom is labeled with a number.

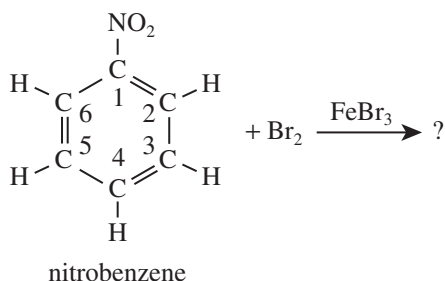

Figure 1

*Student 1*

The  $-NO_2$  partially donates electrons to the benzene ring, resulting in a relatively fast reaction between nitrobenzene and  $Br_2$ . A new C-Br covalent bond is formed when electrons from a carbon atom of the benzene ring are transferred to one of the Br atoms of  $Br_2$ . The reaction produces only 1 carbon-containing product: the H atom bound to C-2 is replaced by a Br atom.

*Student 2*

The  $-NO_2$  partially pulls electrons from the benzene ring, resulting in a relatively slow reaction between nitrobenzene and  $Br_2$ . A new C-Br covalent bond is formed when electrons from a Br atom of  $Br_2$  are transferred to one of the carbon atoms of nitrobenzene. The reaction produces only 1 carbon-containing product: the H atom bound to C-3 is replaced by a Br atom.

*Student 3*

The  $-NO_2$  partially pulls electrons from the benzene ring, resulting in a relatively fast reaction between nitrobenzene and  $Br_2$ . A new C-Br covalent bond is formed when electrons from a carbon atom of the benzene ring are transferred to one of the Br atoms of  $Br_2$ . The reaction produces only 1 carbon-containing product: the H atom bound to C-4 is replaced by a Br atom.

*Student 4*

The  $-NO_2$  partially donates electrons to the benzene ring, resulting in a relatively slow reaction between nitrobenzene and  $Br_2$ . A new C-Br covalent bond is formed when electrons from a Br atom of  $Br_2$  are transferred to one of the carbon atoms in nitrobenzene. The reaction produces 2 carbon-containing products, and each product has only 1 Br atom. In one product, the H atom bound to C-2 is replaced by a Br atom, and in the other product, the H atom bound to C-4 is replaced by a Br atom.

20. Which student indicated that the donation of electrons to the benzene ring results in a relatively fast reaction?
- F. Student 1  
G. Student 2  
H. Student 3  
J. Student 4
21. Which of the following elements is NOT present in the reaction represented in Figure 1 ?
- A. Fluorine  
B. Iron  
C. Nitrogen  
D. Oxygen
22. Consider the structure of *methylbenzene* shown below:

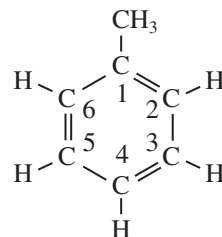

The *methyl group* ( $-CH_3$ ) partially donates electrons to the benzene ring. Based on this information, if methylbenzene were substituted for nitrobenzene in the reaction represented in Figure 1, Student 1 would most likely predict that a Br atom would bond with which carbon atom of methylbenzene?

- F. C-1  
G. C-2  
H. C-3  
J. C-5



23. Which of Students 3 and 4, if either, stated that a covalent bond forms as a result of electrons being transferred from one atom to another?
- Student 3 only
  - Student 4 only
  - Both Student 3 and Student 4
  - Neither Student 3 nor Student 4
24. Consider the carbon-containing product that Student 3 predicted would be formed by the reaction represented in Figure 1. Compared to nitrobenzene, does this product more likely have a smaller molar mass or a greater molar mass?
- Smaller; H has a smaller molar mass than Br, and Student 3 stated that a Br atom is replaced by an H atom.
  - Smaller; Br has a smaller molar mass than H, and Student 3 stated that an H atom is replaced by a Br atom.
  - Greater; H has a greater molar mass than Br, and Student 3 stated that a Br atom is replaced by an H atom.
  - Greater; Br has a greater molar mass than H, and Student 3 stated that an H atom is replaced by a Br atom.
25. Based on Student 2's prediction, which of the following figures shows a product of the reaction represented in Figure 1?
- A.
- C.
- B.
- D.
26. Which of Students 1 and 2, if either, stated that a Br atom replaces a carbon atom in nitrobenzene as a result of the reaction represented in Figure 1?
- Student 1 only
  - Student 2 only
  - Both Student 1 and Student 2
  - Neither Student 1 nor Student 2



### Passage V

Manure mixed with water, known as a *slurry*, is spread on top of a soil to provide additional plant nutrients. The slurry covering alters how rain erodes the ground surface. A study was done on a particular soil with and without slurry on top to determine the amount of *runoff* (water and sediment that runs off the surface) and the concentration of sediment in the runoff during a simulated rainfall event.

#### Study

A volume of the soil was completely dried and then passed through a screen having 9.5 mm diameter openings to remove larger particles. A 25 cm deep layer of the dried, screened soil was placed in each of 2 *flumes* (shallow, flat-bottomed trays) that were 2.5 m long, 1.0 m wide, and 0.3 m deep (see Figure 1). The flumes had a 5% slope. The dried soil in both flumes had a *bulk density* of 1,400 kg/m<sup>3</sup>. Bulk density includes any air or water present in the spaces between the soil particles.

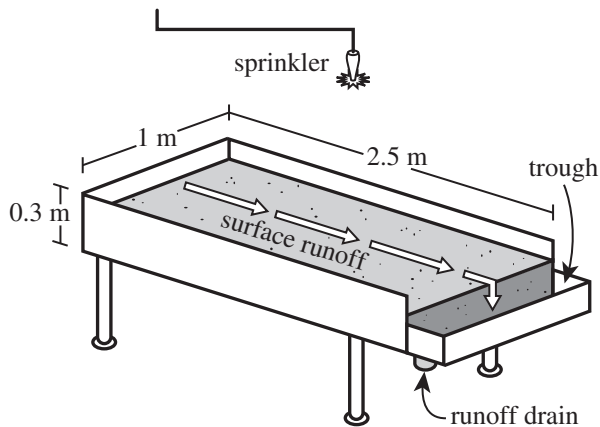

Figure 1

The entire surface of the soil in one of the flumes was then covered with slurry. Once completely dry, it formed a 1 cm thick layer on top of the soil. Next, a sprinkler 2 m above each flume delivered rainfall at a rate of 80 mm/hr for 45 min, after which it was turned off. Over each 5 min of rainfall, all the runoff from the soil was collected from the trough using the runoff drain. For the collected runoff from each 5 min period, the runoff volume, in L, and the concentration of sediment in the runoff, in g/L, was determined. Figure 2 and Figure 3 show the runoff volumes and sediment concentrations, respectively, for each period.

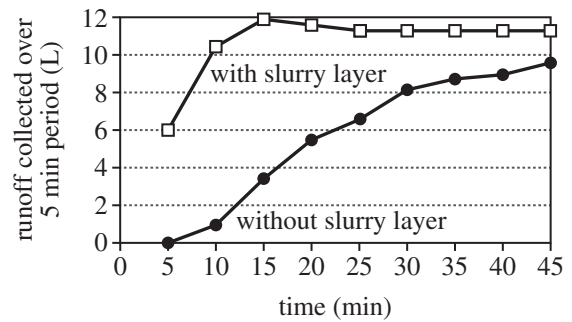

Figure 2

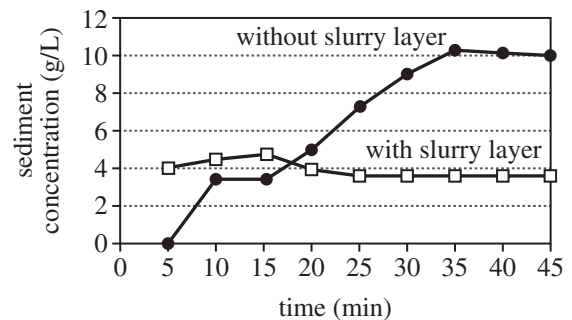

Figure 3

Figures adapted from M. C. Ramos, J. N. Quinton, and S. F. Tyrrel, "Effects of Cattle Manure on Erosion Rates and Runoff Water Pollution by Faecal Coliforms." ©2005 by Elsevier, Ltd.

27. Suppose the study had been repeated with the flumes having a 10% slope. Would the total runoff volume collected from a flume over the first three 5 min periods more likely have been greater than or less than that for the same periods in the original study?
- Greater; a steeper slope would likely cause more runoff to reach the trough sooner than in the original study.
  - Greater; a less steep slope would likely cause more runoff to reach the trough sooner than in the original study.
  - Less; a steeper slope would likely cause less runoff to reach the trough sooner than in the original study.
  - Less; a less steep slope would likely cause less runoff to reach the trough sooner than in the original study.





28. Based on the results of the study, was the average runoff over the entire 45 min of rainfall for the flume with the slurry layer greater than or less than that for the flume without the slurry layer, and was the average sediment concentration over the entire 45 min of rainfall for the flume with the slurry layer greater than or less than that for the flume without the slurry layer?
- |    | <u>average runoff<br/>with slurry</u> | <u>average sediment<br/>concentration with slurry</u> |
|----|---------------------------------------|---|
| F. | greater                               | greater   |
| G. | greater                               | less  |
| H. | less                                  | greater   |
| J. | less                                  | less  |
29. Consider the information provided about bulk density. Based on that information, would the bulk density of  $1.0 \text{ m}^3$  of the soil in the flume without a slurry layer more likely have been greater than  $1,400 \text{ kg/m}^3$  or less than  $1,400 \text{ kg/m}^3$  at the end of the 45 min of rainfall?
- A. Greater; some water would have soaked in, increasing the density.  
 B. Greater; some soil particles would have been dissolved, decreasing the density.  
 C. Less; some water would have soaked in, decreasing the density.  
 D. Less; some soil particles would have been dissolved, increasing the density.
30. All the particles in the dried soil that passed through the screen had a diameter of:
- F. less than or equal to 9.5 mm.  
 G. exactly 9.5 mm.  
 H. between 9.5 mm and 12 mm.  
 J. greater than 12 mm.
31. According to the results of the study, the greatest difference between the sediment concentrations of the samples collected at the same time from the 2 flumes was closest to which of the following?
- A. 2 g/L  
 B. 4 g/L  
 C. 6 g/L  
 D. 8 g/L
32. In the study, what was the total depth of water, in mm, produced by a sprinkler over the 45 min of rainfall?
- F. 20 mm  
 G. 40 mm  
 H. 60 mm  
 J. 80 mm
33. Which of the following expressions best represents the volume of material in the flume with the slurry layer just before the rainfall began?
- A.  $2.0 \text{ m} \times 1 \text{ m} \times 0.25 \text{ m}$   
 B.  $2.0 \text{ m} \times 1 \text{ m} \times 0.26 \text{ m}$   
 C.  $2.5 \text{ m} \times 1 \text{ m} \times 0.25 \text{ m}$   
 D.  $2.5 \text{ m} \times 1 \text{ m} \times 0.26 \text{ m}$



### Passage VI

In each of 3 experiments, students studied the motion of pendulums. Each pendulum was a solid sphere on a string. Each pendulum had a mass,  $M$ , equal to the mass of its sphere and a length,  $L$ , equal to the length of its string plus the radius of its sphere (see the diagram).

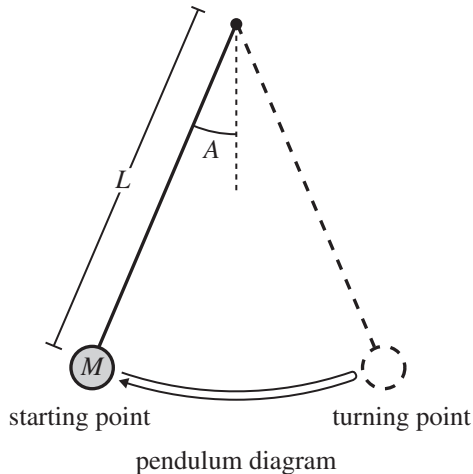

The students performed the following steps for each pendulum tested in Experiments 1–3:

1. Student 1 moved the pendulum until its string made an angle,  $A$ , with the vertical and then released the pendulum from rest.
2. Student 1 timed the pendulum for 10 *full swings* (one full swing was from the starting point to the turning point and back). Student 1 then divided that time by 10 to obtain the *average period*,  $T$ , for the pendulum.
3. Student 2 solved the *simple pendulum equation* for the pendulum tested in Steps 1 and 2. (The simple pendulum equation is a relation that predicts the value of  $T$  for a pendulum based on its physical characteristics.)

#### Experiment 1

The students tested several pendulums:  $L$  was 100 cm for each, but  $M$  was different for each. Student 1 released each pendulum from  $A = 10^\circ$ . Figure 1 shows the values of  $T$ , in seconds (s), that Student 1 measured and those that Student 2 calculated.

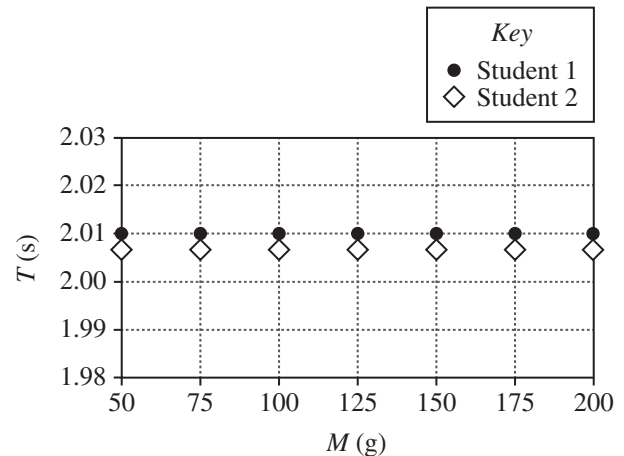

Figure 1

#### Experiment 2

The students tested several pendulums:  $M$  was 100 g for each, but  $L$  was different for each. Student 1 released each pendulum from  $A = 10^\circ$ . Figure 2 shows the students' results.

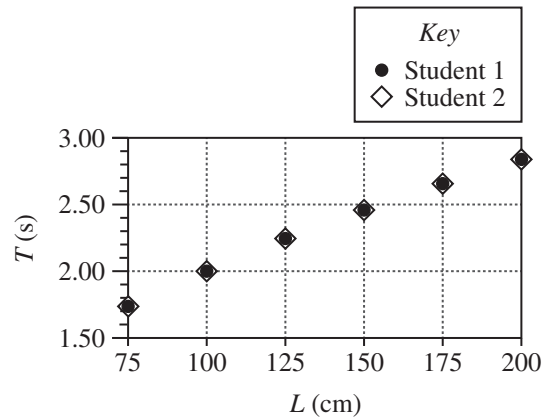

Figure 2

#### Experiment 3

The students tested several pendulums:  $M$  was 100 g for each, and  $L$  was 100 cm for each. Student 1 released each pendulum from a different  $A$ . Figure 3 shows the students' results.

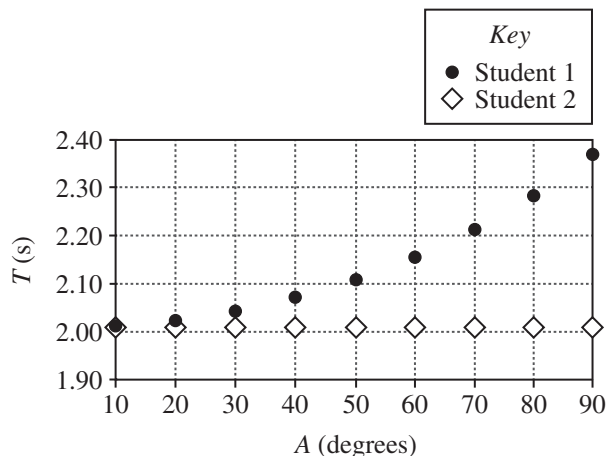

Figure 3

34. Consider the results of Experiments 2 and 3. A comparison of Student 1's data with Student 2's data indicates that the simple pendulum equation becomes *less* accurate as the:

F. starting angle increases.  
 G. starting angle decreases.  
 H. string length increases.  
 J. string length decreases.

35. Suppose that in Experiment 2, Student 2 had obtained a period of 2.60 s for a pendulum having a mass of 100 g. The length of this pendulum would most likely have been closest to which of the following values?

A. 140 cm  
 B. 170 cm  
 C. 190 cm  
 D. 220 cm

36. Consider the pendulum illustrated in the following diagram.

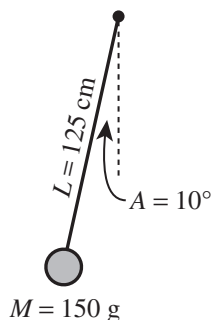

In which experiment(s), if any, was this pendulum tested?

F. Experiment 3 only  
 G. Experiments 1 and 2 only  
 H. Experiments 1, 2, and 3  
 J. None of the experiments

37. Which of the following statements best summarizes the results of Experiment 1? Compared to the values of  $T$  obtained by Student 1, Student 2 consistently obtained values of  $T$  that were:

A. greater, and the size of the difference between Student 1's value and Student 2's value increased as pendulum mass decreased.  
 B. greater, and the size of the difference between Student 1's value and Student 2's value remained constant regardless of pendulum mass.  
 C. smaller, and the size of the difference between Student 1's value and Student 2's value increased as pendulum mass decreased.  
 D. smaller, and the size of the difference between Student 1's value and Student 2's value remained constant regardless of pendulum mass.

38. Which pendulum tested in Experiment 1, if any, was released with the greatest gravitational potential energy?

F. The 50 g pendulum  
 G. The 125 g pendulum  
 H. The 200 g pendulum  
 J. None of the pendulums; each pendulum was released with the same gravitational potential energy.

39. In order for the students to have completed Experiments 1–3 as described, what was the minimum number of *different* spheres necessary, and what was the minimum number of *different* strings necessary?

	minimum number of spheres	minimum number of strings
A.	7	6
B.	7	8
C.	9	6
D.	9	8

40. Consider the vertical axes of Figures 1, 2, and 3. The greater the *resolution* of a given axis, the smaller the differences in time that can be clearly shown on that axis. The vertical axis of which figure, if any, is drawn with the greatest resolution?

F. Figure 1  
 G. Figure 2  
 H. Figure 3  
 J. None of the figures; each figure's vertical axis is drawn with the same resolution.

**END OF TEST 4**

**STOP! DO NOT RETURN TO ANY OTHER TEST.**



# April 2023 (Z18) ACT Answer Key

## ENGLISH

1. C	14. J	27. C	40. J	53. A	66. G
2. H	15. B	28. J	41. C	54. H	67. B
3. A	16. H	29. D	42. J	55. A	68. F
4. J	17. B	30. G	43. A	56. J	69. D
5. A	18. G	31. B	44. G	57. A	70. G
6. G	19. A	32. G	45. C	58. G	71. D
7. A	20. H	33. C	46. J	59. C	72. F
8. F	21. C	34. G	47. B	60. J	73. D
9. C	22. G	35. A	48. F	61. D	74. H
10. J	23. A	36. J	49. B	62. F	75. C
11. A	24. F	37. A	50. J	63. C	
12. J	25. B	38. J	51. C	64. J	
13. C	26. F	39. A	52. J	65. A	

## MATH

1. E	11. B	21. D	31. C	41. B	51. A
2. G	12. H	22. K	32. H	42. J	52. H
3. B	13. C	23. B	33. D	43. C	53. E
4. K	14. K	24. F	34. F	44. J	54. H
5. D	15. E	25. B	35. D	45. A	55. D
6. G	16. H	26. G	36. H	46. G	56. F
7. B	17. A	27. A	37. D	47. B	57. A
8. K	18. G	28. H	38. F	48. J	58. K
9. B	19. E	29. D	39. D	49. E	59. E
10. H	20. K	30. G	40. J	50. K	60. J

## READING

1. C	8. F	15. B	22. J	29. B	36. J
2. G	9. B	16. J	23. C	30. H	37. B
3. D	10. J	17. C	24. H	31. C	38. H
4. H	11. A	18. G	25. C	32. F	39. D
5. C	12. F	19. A	26. J	33. B	40. H
6. J	13. D	20. J	27. B	34. J	
7. C	14. F	21. D	28. F	35. A	

## SCIENCE

1. D	8. F	15. D	22. G	29. A	36. J
2. F	9. C	16. G	23. C	30. F	37. D
3. C	10. H	17. B	24. J	31. C	38. H
4. J	11. D	18. F	25. B	32. H	39. A
5. C	12. G	19. B	26. J	33. D	40. F
6. H	13. C	20. F	27. A	34. F	
7. D	14. J	21. A	28. G	35. B	

## ACT Resource Links

**ACT Online Practice Tests:** <https://www.crackab.com/act/>

✧ **ACT English Practice Tests:**

<https://www.crackab.com/act/english/>

✧ **ACT Math Practice Tests:**

<https://www.crackab.com/act/math/>

✧ **ACT Reading Practice Tests:**

<https://www.crackab.com/act/reading/>

✧ **ACT Science Practice Tests:**

<https://www.crackab.com/act/science/>

**ACT Grammar:** <https://www.crackab.com/act/grammar/>

**ACT Real Past Papers Download:**

<https://www.crackab.com/act-downloads/>

**More ACT Practice Tests Online:** <https://www.actexam.net>

---

**Digital SAT & New SAT Practice Tests:**

<https://www.cracksat.net>

**Real SAT Tests Download:**

<http://www.cracksat.net/sat-downloads/>

**AP Exams Practice Tests:**

<https://www.crackap.com>

<https://www.apstudy.net>

## Explanation of Procedures Used to Obtain Scale Scores from Raw Scores

On each of the four tests on which you marked any responses, the total number of correct responses yields a raw score. Use the table below to convert your raw scores to scale scores. For each test, locate and circle your raw score or the range of raw scores that includes it in the table below. Then, read across to either outside column of the table and circle the scale score that corresponds to that raw score. As you determine your scale scores, enter them in the blanks provided on the right. The highest possible scale score for each test is 36. The lowest possible scale score for any test on which you marked any responses is 1.

Next, compute the Composite score by averaging the four scale scores. To do this, add your four scale scores and divide the sum by 4. If the resulting number ends in a fraction, round it off to the nearest whole number. (Round down any fraction less than one-half; round up any fraction that is one-half or more.) Enter this number in the blank. This is your Composite score. The highest possible Composite score is 36. The lowest possible Composite score is 1.

ACT Test Z18	Your Scale Score
English	_____
Mathematics	_____
Reading	_____
Science	_____
<b>Sum of scores</b> _____	
<b>Composite score (sum ÷ 4)</b> _____	

NOTE: If you left a test completely blank and marked no items, do not list a scale score for that test. If any test was completely blank, do not calculate a Composite score.

Scale Score	Raw Scores				Scale Score
	Test 1 English	Test 2 Mathematics	Test 3 Reading	Test 4 Science	
36	74-75	59-60	39-40	40	36
35	71-73	57-58	38	39	35
34	70	55-56	37	38	34
33	69	53-54	36	37	33
32	68	52	35	36	32
31	67	51	—	35	31
30	66	49-50	34	—	30
29	65	47-48	33	34	29
28	64	45-46	32	33	28
27	63	43-44	—	32	27
26	61-62	40-42	31	30-31	26
25	59-60	38-39	30	29	25
24	56-58	35-37	28-29	26-28	24
23	53-55	33-34	27	24-25	23
22	51-52	32	25-26	22-23	22
21	47-50	30-31	24	21	21
20	45-46	28-29	22-23	19-20	20
19	42-44	26-27	21	17-18	19
18	40-41	24-25	20	16	18
17	38-39	21-23	18-19	14-15	17
16	35-37	17-20	17	13	16
15	32-34	13-16	15-16	12	15
14	29-31	11-12	14	11	14
13	27-28	8-10	12-13	10	13
12	24-26	7	10-11	9	12
11	21-23	6	9	7-8	11
10	17-20	5	8	6	10
9	15-16	4	7	5	9
8	13-14	3	6	—	8
7	10-12	—	5	4	7
6	8-9	2	4	3	6
5	6-7	—	3	2	5
4	5	1	—	—	4
3	3-4	—	2	1	3
2	2	—	1	—	2
1	0-1	0	0	0	1